



As a furniture designer, BRAM KERKHOFS (° 1977, Belgium) is looking for new forms and methods to challenge the functionality and flexibility of a piece of furniture. He is fascinated by connections, hinges and joints and in particular by the modularity that these generate. Form, concept, technique and material are always related to each other, with a permanent alertness to the ultimate function and need. This time-intensive design and development process always results in unique systems that automatically carry out his signature. Many of his designs are parts that have to be seen in a larger whole. He explores the possibilities of links and combinations in which a design should not only be seen as an isolated object but as an element in an often infinite combination. Bram is looking for innovative creative solutions. Often in form, space, construction and material, but in addition he also devises tailor-made concepts, in which he links form, function and technology to certain situations or contexts. Bram believes in the power for design to be a problem-solving tool. Following on this idea Bram puts a lot of effort in design education and education through design on all levels.

# SAWA

a furniture collection with a soul

## SAWA | the workshop

A collaborative project between Bram Kerkhofs and March at Minjara (Tripoli, Lebanon) from 02/12/2019 until 09/12/2019.

Sawa is Arabic for together. It symbolizes the fact that it helps people from two hostile areas in Tripoli to reconcile. This is achieved by letting them work together on different modular furniture objects. The modular system that forms the base of each design, symbolizes perfectly the social cohesion necessary to succeed. It starts from the use of round shaped beams with a varying diameter from 20 to 120 millimeters. Each diameter is made of a different kind of wood. The smaller the section, the stronger the wood. The dimensions used in the system are based on the well-balanced proportions in Roman architecture. A balance which is also achieved in the furniture and between the participants in this project.

### SAWA's system

Sawa's modular system starts from a simple connection of two beams using metal screw threaded rods and cross dowels. Using this system two beams either form a T connection or can pass through another one.

Each designed piece of furniture needs its own specific parts to be assembled following its instruction manual. An object will only work if all steps are followed precisely.

SAWA's social purpose is about learning from each other, about commitment, pride and ownership. It is also about learning and combining skills, starting from and with respect for everyone's individuality, strengths and weaknesses.

Sawa is an all-embracing project with a profound social and creative layering, it is both ethical and esthetical. It creates opportunities, works reconciling, can only work through collaboration and sharpens mathematical and spatial skills. For this workshop Bram has been assisted by one staff member from March to guide 11 people between the age of 19 and 25.

#### About MARCH

MARCH is an active and creative non-profit organization that promotes social cohesion and personal freedom in the most marginalized areas Bab el Tabbaneh and Jabal Mohsen in Tripoli. On the former line of fire where two militias took each other under fire a few years ago, there is now Kahwatna, a café, meeting room and creative outlet for the youngsters (and the older people) of the neighborhood. The men and women who participate in the project learn all kinds of building skills, among other things, but they also invest in learning English and the power of living together.

The shopping street and the public spaces in the neighborhood have already been tackled. The holistic approach, and the emphasis on social and economic rehabilitation, has made the neighborhood revive and makes everyone, from the returned Syria fighter to the former militant, regain his value and hope for the future. Art and culture are used as tools to achieve these goals.

MARCH team is ambitious and proud of their city. They want to bring people to Tripoli and that is why they want to open an attractive B&B in their Kahwatna. They are going to rebuild and design it themselves, but seek inspiration and coaching from professionals. MARCH believes in the power of art to promote tolerance, dialogue and personal development. Bram Kerkhofs was invited to work out this interesting experiment and to guide it on the spot.

[www.marchlebanon.org](http://www.marchlebanon.org)



#### About MINJARA

MINJARA is a workshop that was created with the help of the European Union to revive the dying traditional woodworking crafts in Tripoli by setting up collaborations with contemporary designers and bringing them into contact with traditional makers. It has an innovative machine park where designers can come and experiment and then collaborate with the local craftsmen. This way of working confronts them with more modern forms and ideas.

The workplace is in one of the buildings on the International Fairground, an immense but inaccessible park with a dozen architectural concrete structures by Oscar Niemeyer.

[www.minjara.com/](http://www.minjara.com/)



## SAWA THE COLLABORATION

SAWA refers to the Arabic word for “together” from the collaboration between young people and from the modular construction system that forms the basis for the furniture objects.

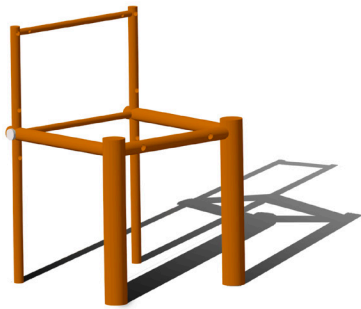

C1.  
mea



T1.  
mea

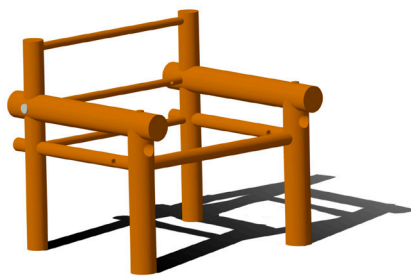

C2.  
mea

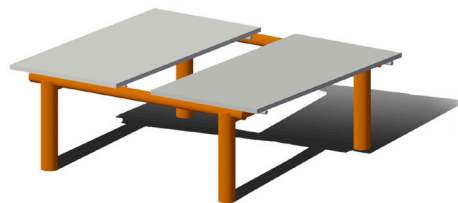

T2.  
mea

# SAWA` THE OBJECTS

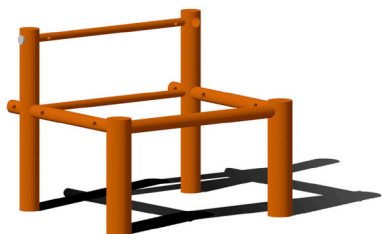

C3.  
mea

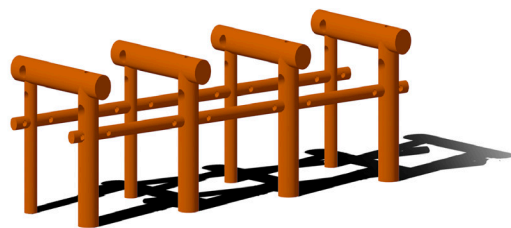

B1.  
mea

SAWA  
creates opportunities  
develops skills  
promotes cooperation  
works reconciling  
only works together

B2.  
mea

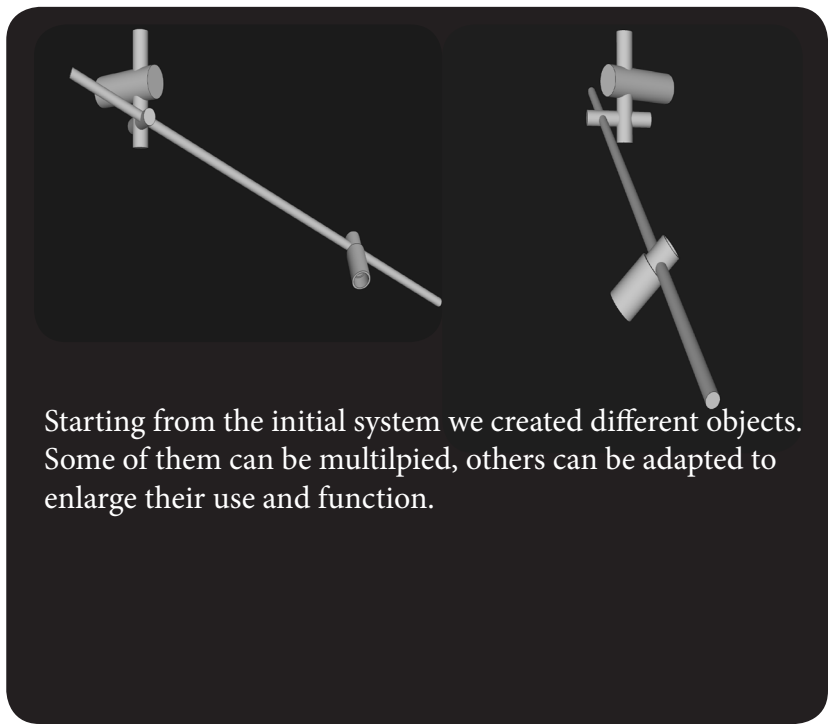
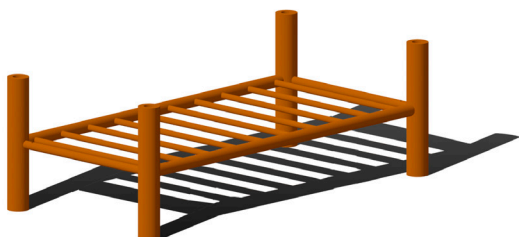

Starting from the initial system we created different objects. Some of them can be multiplied, others can be adapted to enlarge their use and function.

# SAWA





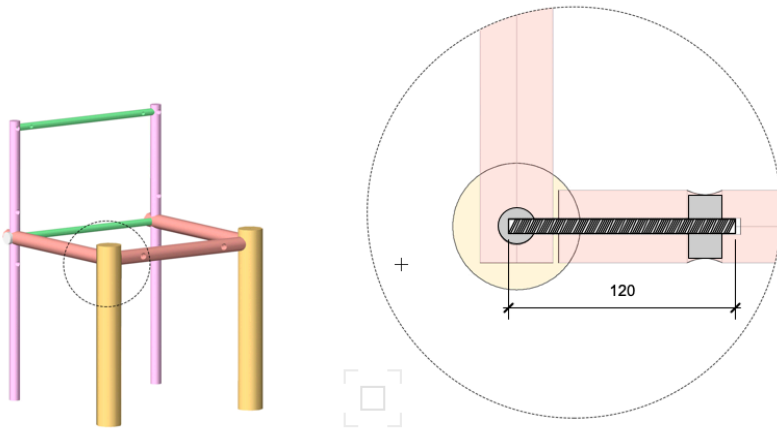





## THE MODULAR SYSTEM

Sawa starts from cylindrical round beams in 10 different diameters: 20, 30, 40, 50, 60, 70, 80, 90, 100 and 100 millimeters. There is a different type of wood for each diameter. On the one hand in function of the strength and stiffness of the component, on the other hand as a reference to the diversity within the concept from its participants. The construction consists of a coupling of two beams with cross nuts and a threaded rod and allows two beams to be connected to each other in positions of 90° and 180° relative to each other.



Bram Kerkhofs Design Studio - MARCH		
C1 - Detail2	ref : reference sheet	
Units : mm	M8	Page 11/11



	Wood stick's	Metal plug's		
High quality wood	● 20 mm		M6	
	● 30 mm		M6	
	● 40 mm		M8	
	● 50 mm		M8	
	● 60 mm		M8	
	● 70 mm		M8	
	● 80 mm		M8	
	● 90 mm		M8	
	Low quality wood	● 90 mm		M8
		● 100 mm		M8

Bram Kerkhofs Design Studio - MARCH	
Reference sheet	Page 1/1
Units : mm	Scale : 1:5



C1.  
L&S

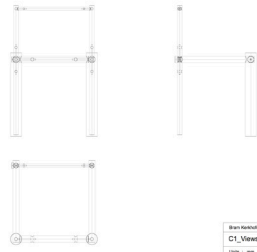

Bram Kerkhofs Design Studio - MARCH  
C1\_VIEWS ref : reference sheet  
Units : mm Scale : 1:10 Page 11/13

1

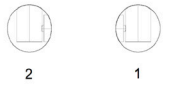
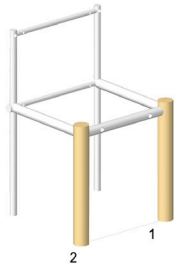
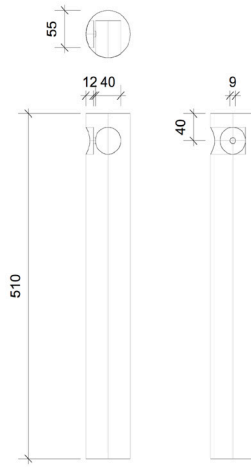

Bram Kerkhofs Design Studio - MARCH  
C1 - Part1 ref : reference sheet  
Units : mm Scale : 1:5 Page 4/13

Pagina 5 van 14

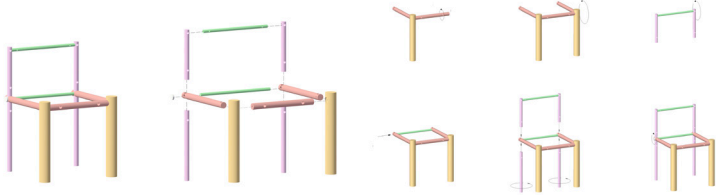

Bram Kerkhofs Design Studio - MARCH  
C1\_Fullset view ref : reference sheet  
Units : mm Scale : 1:5 Page 9/13

Bram Kerkhofs Design Studio - MARCH  
C1\_Building process ref : reference sheet  
Units : mm Scale : 1:5 Page 9/13

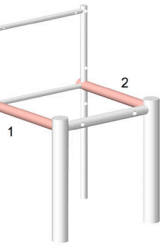
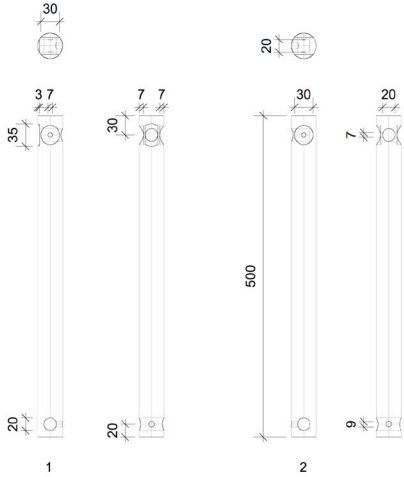

2x metal plugs

Bram Kerkhofs Design Studio - MARCH  
C1 - Part2 ref : reference sheet  
Units : mm Scale : 1:5 Page 5/13

Pagina 6 van 14

SAWA goes much further than just creation. It is based on the power of cooperation and is about learning from each other, about involvement, pride and ownership, about learning skills, starting from and with respect for everyone's individuality, strengths and weaknesses. SAWA is a "gesamt" project with a deep social and creative stratification, based on ethics and aesthetics with great human value. Through this approach Sawa only works 'together', combining different skills from different personalities.

## SAWA THE METHOD

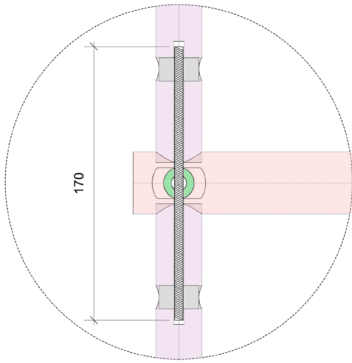
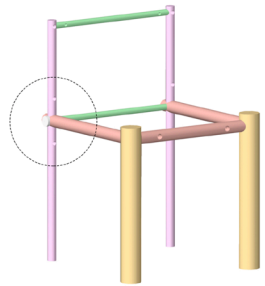

Bram Kerkhofs Design Studio - MARCH  
C1 - Detail1 ref : reference sheet  
Units : mm M6 Page 10/13

Pagina 11 van 14

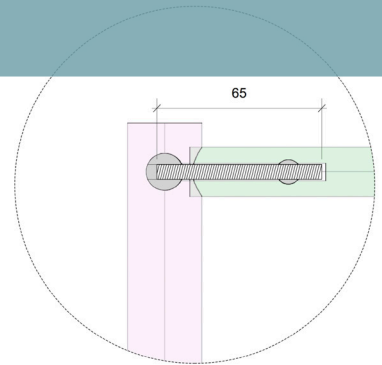
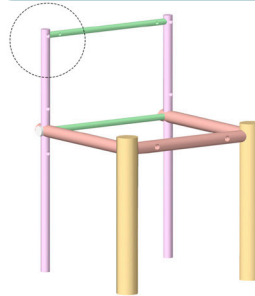

Bram Kerkhofs Design Studio - MARCH  
C1 - Detail3 ref : reference sheet  
Units : mm M6 Page 12/13

Pagina 13 van 14

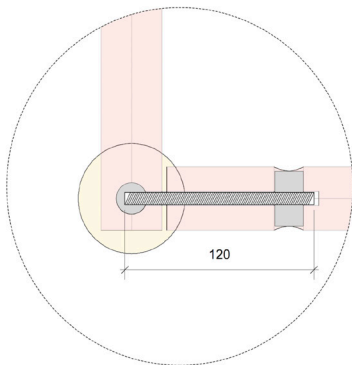
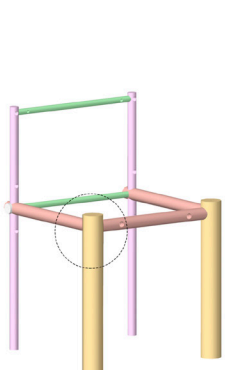

Bram Kerkhofs Design Studio - MARCH  
C1 - Detail2 ref : reference sheet  
Units : mm M8 Page 11/13

Pagina 12 van 14

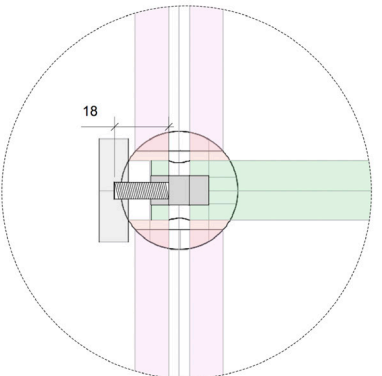
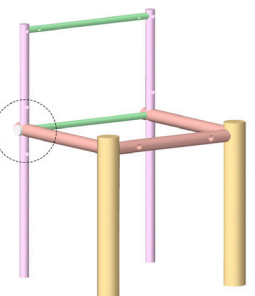

Bram Kerkhofs Design Studio - MARCH  
C1 - Detail4 ref : reference sheet  
Units : mm M6 Page 13/13

Pagina 13 van 14