



ORBITA™



- 4 **ORBITA**

- 6 **ALLINEAMENTI (9 MAY 1126)**
Oval table

- ECLITTICA BIANCA / NERA**
Oval table

- 16 **LUNA ROSSA (27 JULY 2018)**
Round table

- LUNA BIANCA / NERA**
Round table



ORBITA™

The "Orbita" collection stems from the desire to create highly representative tables by attributing the poetic idea of form to functionality. The "Eclittica" table, without planets, leaves the sun as the sole protagonist. "Allineamenti" reinterprets one of the rare configurations in the sky, when all the planets find themselves arranged along an imaginary line.

The basic concept is the unavoidable merging of form and decoration, that arose from the idea that the elliptical shape of the crystal surface outlines the orbit of the planets around the Sun. The whole top is in stratified crystal and beveled in the lower part, decorated with two-grained golden powders and variegated metal leaves to represent the planets of the solar system. At the base, there is an internally lit truncated cone, covered in gold-colored leaf to symbolize the Sun, while on the outer perimeter there is a pillar that seems to come out of the surface.

Various graphics have been developed for "Eclittica": tones that recall the celestial darkness illuminated by a dusting of fine golden powder or the colour white, which emphasizes the intensity of the light emanating from the base (Sun). The variants of "Orbita" are expressed in the Luna Nera, Luna Bianca and Luna Rossa concepts, with the latter also offering the possibility of representing the astral position on any date.

“

*Here today, tomorrow elsewhere.
Always in motion. A voyage
that returns once more
to the beginning.*

*Dancing together, in perfect
asynchronicity. Around the core, so
many identities caressed by the golden
rays. Surrounded by darkness.*

”

 **ORBITA**[™]
ALLINEAMENTI / ECLITTICA

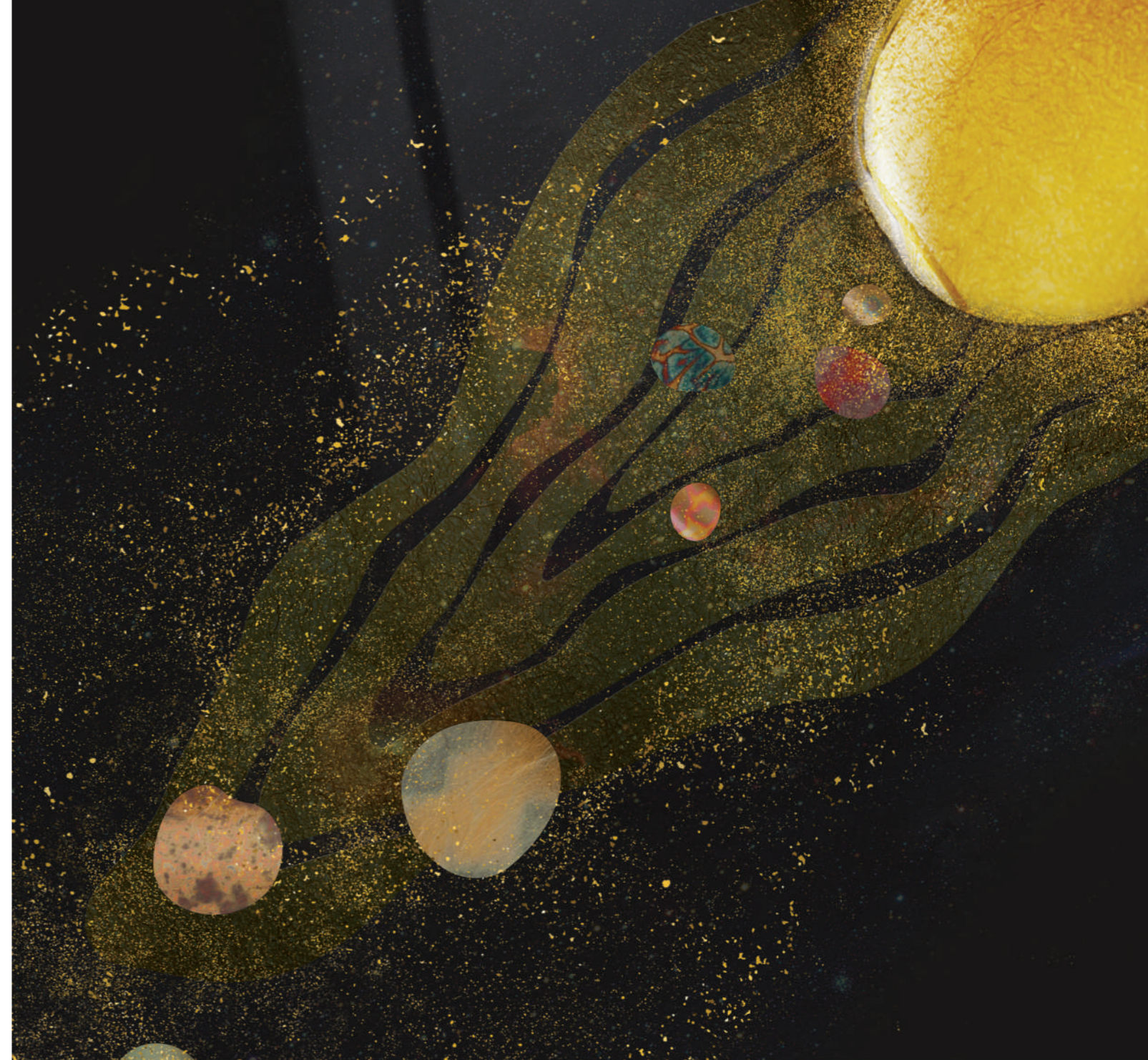

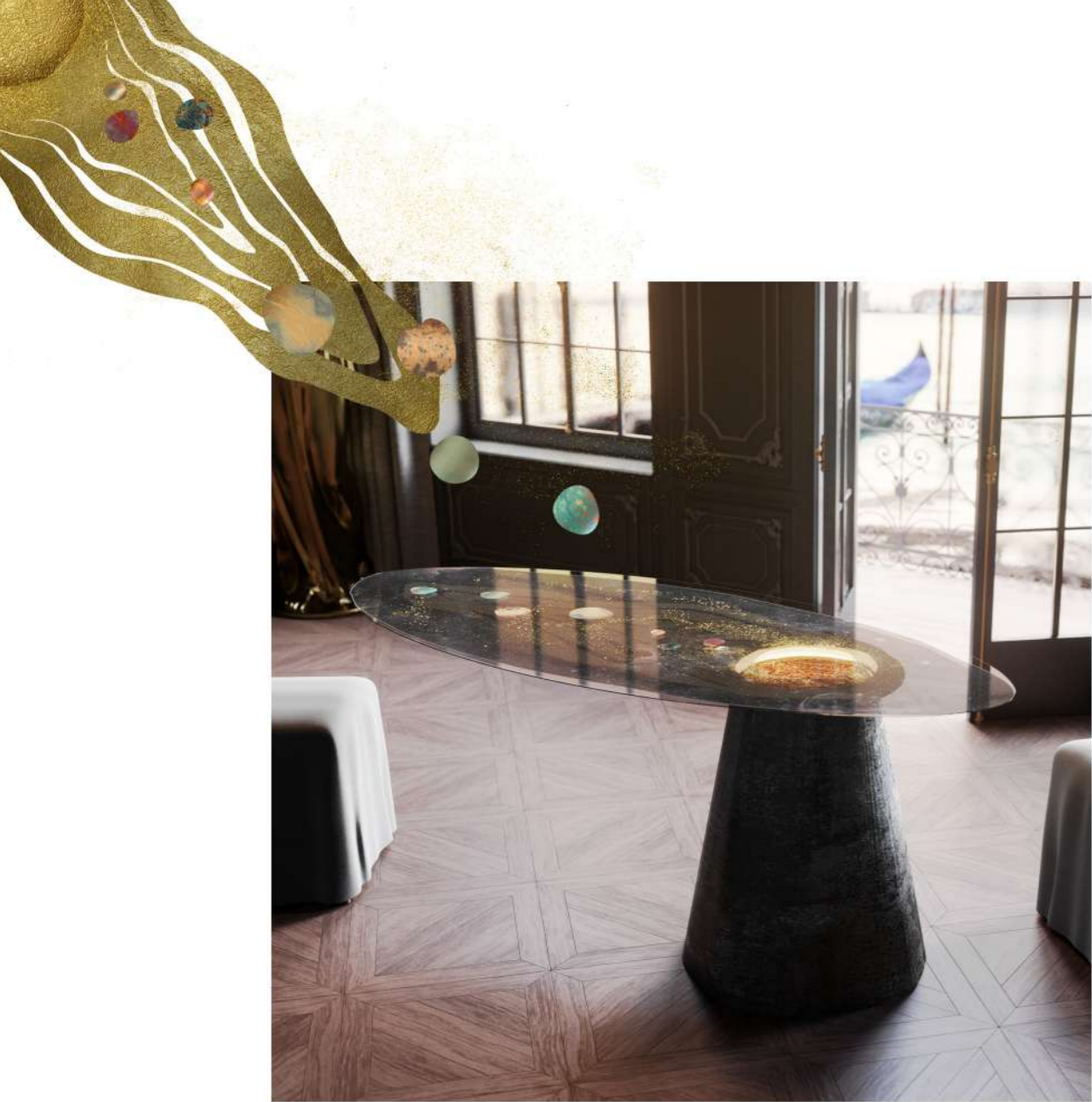

TABLE
ALLINEAMENTI
(9 MAY 1126)





(9 MAY 1126)

ALLINEAMENTI™

"ORBITA" COLLECTION



Designers CAROLA FUMAROLA and UNICA

Product features Table with extra-clear glass top, bevelled below, layered, thickness 20 mm. (10+10), decorated with sandblasting, varied texture in digital printing on gold coloured leaf, shading in digital printing and *Trilli Effect* (golden powder) applied on the upper glass.

Stainless steel structure, thickness 5 mm., with soft touch matt black paint outside and gold coloured leaf finishing inside. Aluminium plate thickness 30 mm., shaped with waterjet cut and bevelling by hand, soft touch matt black paint on the outer edge and top covered with gold coloured leaf.

Interior lighting with warm light 15 W led with battery.

Dimensions L. 220 cm W. 95 cm H. 80 cm **Weight** 150 kg

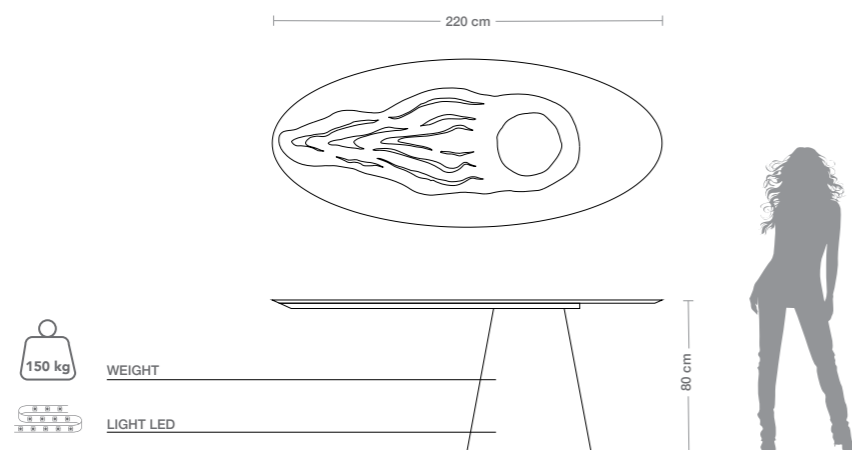

Top

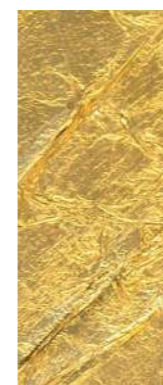

Golden Leaf



Trilli Effect



Varied texture in digital printing on gold coloured leaf



Sandblasting



Digital Printing

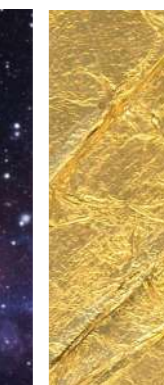

Golden Leaf



Soft touch matt black paint

Base



TABLE
ECLITTICA NERA

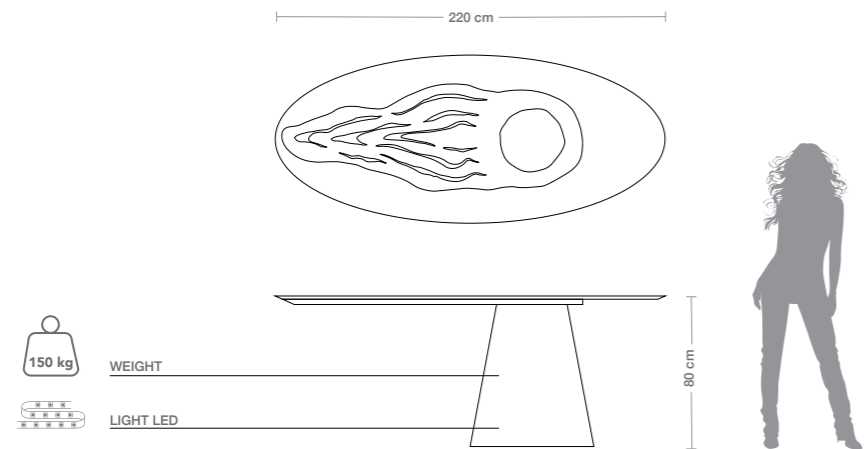

ECLITTICA™

"ORBITA" COLLECTION



Designers CAROLA FUMAROLA and UNICA

Product features Table with extra-clear glass top, bevelled below, layered, thickness 20 mm. (10+10), decorated with sandblasting, transparent white / black paint and *Trilli Effect* (golden powder) applied on upper glass.

Stainless steel structure, thickness 5 mm., with soft touch matt white / black paint outside and gold coloured leaf finishing inside. Aluminium plate thickness 30 mm., shaped with waterjet cut and bevelling by hand, soft touch matt white / black paint on the outer edge and top covered with gold coloured leaf.

Interior lighting with warm light 15 W led with battery.

Dimensions L. 220 cm W. 95 cm H. 80 cm **Ballast** 150 kg

Top

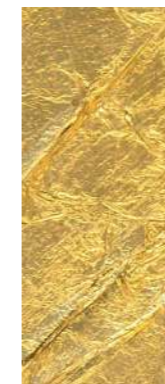

Golden Leaf



Trilli Effect



Transparent White / Black Painting



Sandblasting

Base



Golden Leaf

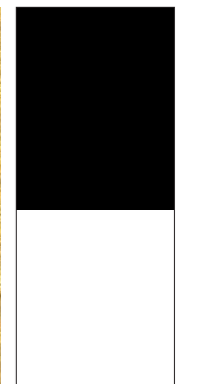

Soft touch matt white / black

“

*For millennia, man has looked up
to the sky and probed its depth.*

*He discovers new worlds, traces routes
between the stars, and outlines
the planets.*

”



LUNA ROSSA / LUNA BIANCA / LUNA NERA





TABLE
LUNA ROSSA



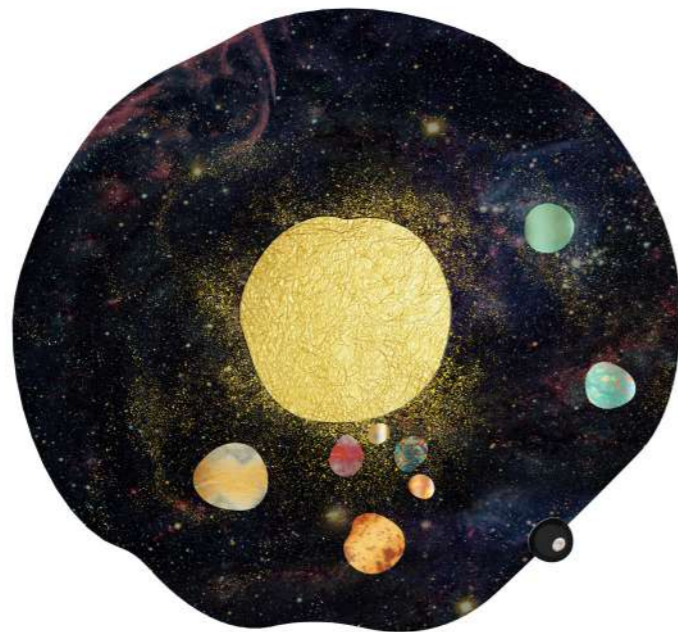

(27 JULY 2018)

LUNA ROSSA™

"ORBITA" COLLECTION



Designers CAROLA FUMAROLA and UNICA

Product features Table with extra-clear glass top, bevelled below, layered, thickness 20 mm. (10+10), decorated with sandblasting, varied texture in digital printing on gold coloured leaf, shading in digital printing and *Trilli Effect* (golden powder) applied on the upper glass.

Double stainless steel structure, thickness 2 mm., wooden core, with soft touch matt black paint outside and gold coloured leaf finishing inside.

Interior lighting with warm light 15 W led with battery.

Dimensions L. 160 cm W. 160 cm H. 80 cm

Weight 197 kg

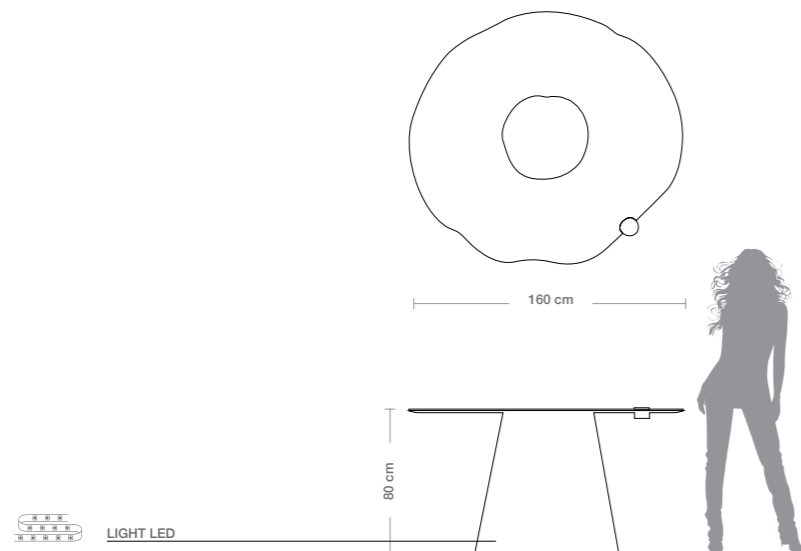

Top

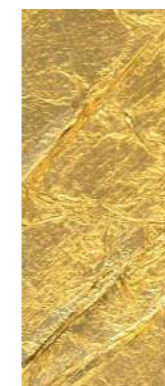

Golden Leaf



Trilli Effect



Fumè



Varied texture in digital printing on gold coloured leaf



Sandblasting



Digital Printing

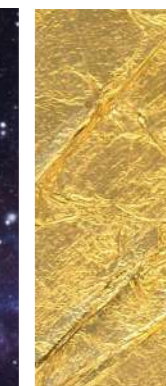

Golden Leaf



Soft touch matt black paint

Base

LUNA BIANCA / NERA™

"ORBITA" COLLECTION



Designers CAROLA FUMAROLA and UNICA

Product features Table with extra-clear glass top, bevelled below, layered, thickness 20 mm. (10+10), decorated with sandblasting, transparent white / black paint, *Trilli Effect* (golden powder) applied on upper glass.

Double stainless steel structure, thickness 2 mm. and wooden core, with soft touch matt black paint outside and gold coloured leaf finishing inside.

Interior lighting with warm light 15 W led with battery.

Dimensions L. 160 cm W. 160 cm H. 80 cm

Weight 197 kg

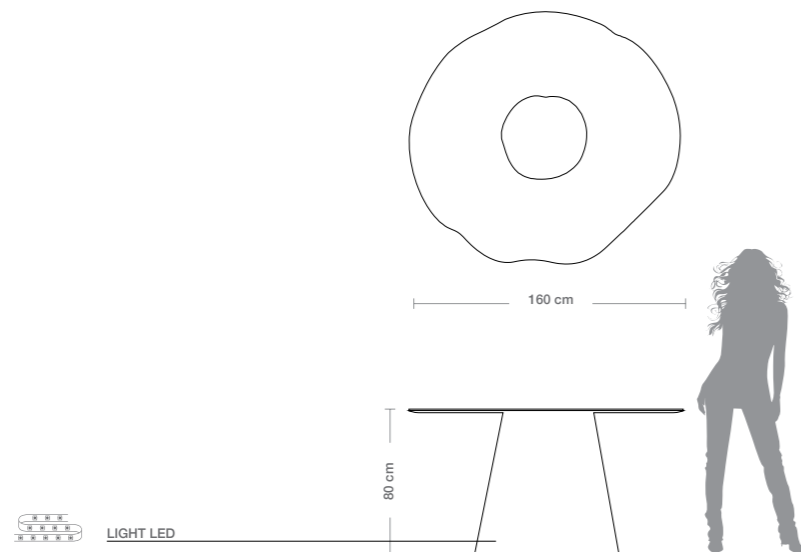

Top

Base

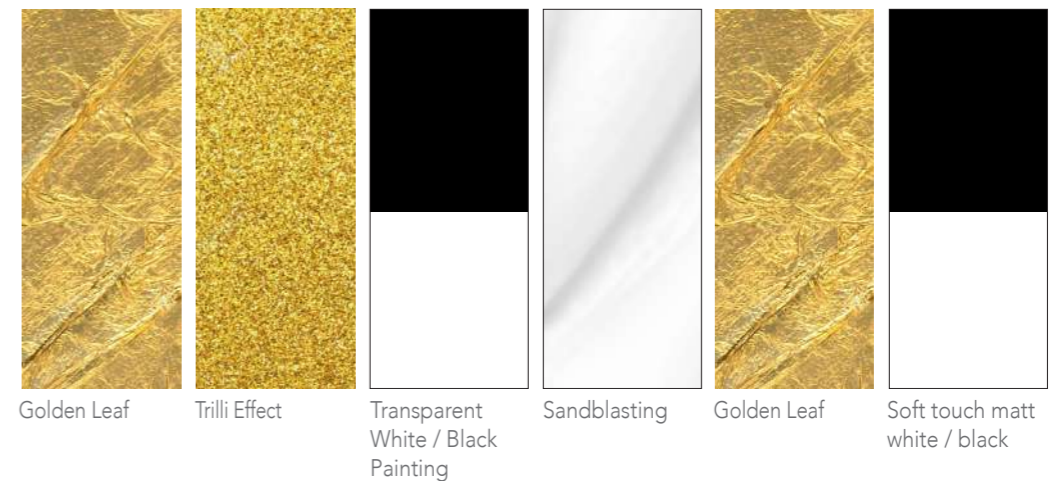



Luxury Bespoke Tables

VIA BONAZZI 4, CASTEL MAGGIORE (BO) 40013 ITALY
T. +39 051/0930627 INFO@UNICA.BIZ WWW.UNICA.BIZ



PROJECT CO-FINANCED BY

CAMERE DI COMMERCIO DELL'EMILIA-ROMAGNA AND BY REGIONE EMILIA-ROMAGNA



UNIONCAMERE
EMILIA-ROMAGNA



Regione Emilia-Romagna

MADE IN ITALY