

**DIESEL**

**LIVING**

**WITH**

2021 LIGHTING ASSORTMENT

**LODES**



WITH  
LODES

# DIESEL LIVING

A versatile range of lamps for homes and public interiors celebrates the partnership between Diesel Living and Lodes. Today, the unmistakable Diesel language takes new contemporary and dynamic forms and tells fresh stories through light. Rock and pop, fun and functional, casual and industrial, the Diesel creative intuition brings an irreverent lifestyle touch to a vibrant lighting collection.



Una collezione versatile di lampade d'arredo d'interni privati e pubblici celebra la partnership tra Diesel Living e Lodes. L'inconfondibile linguaggio Diesel assume oggi nuove forme dinamiche e contemporanee per raccontare inedite storie di luce. Rock e pop, giocosa e funzionale, casual e industriale, l'intuizione creativa di Diesel regala il suo tocco lifestyle irriverente a una frizzante gamma di lampade.

# 2021 LIGHTING ASSORTMENT



Comprising of three exclusive additions (Flask, Vinyl and Urban Concrete) as well as five renovated best sellers (Cage, Fork, Gask, Glass Drop and Pipe), the new Diesel Living with Lodes collection features a versatile selection of lighting pieces for residential spaces and public interiors. The collection is inspired by contrasting opposites, such as reality and perception, whilst imbued with DIESEL's irreverent directional design language and Lodes' distinctive brand tenets.

All lamps are designed for the use of commercial light bulbs, leaving complete freedom of choice on the type of light. We provide the emotion, you choose the light source!

Composta da tre novità esclusive (Flask, Vinyl e Urban Concrete) e da cinque best seller rinnovati (Cage, Fork, Gask, Glass Drop e Pipe), la nuova collezione Diesel Living with Lodes presenta una versatile selezione di articoli per l'illuminazione di spazi residenziali e di interni pubblici. La collezione si ispira ad antitetici contrasti, come la realtà e la percezione, ed è permeata dall'irriverente e direzionale linguaggio formale di DIESEL combinato con i principi distintivi del brand Lodes. Tutte le lampade sono predisposte per l'utilizzo di lampadine commerciali, per lasciare completa libertà di scelta sul tipo di luce. Noi offriamo l'emozione, voi scegliete la fonte luminosa!

**CAGE**<sup>6</sup>  
**FLASK**<sup>14</sup>

**FORK**<sup>24</sup>

**GASK**<sup>34</sup>

**GLASS DROP**<sup>42</sup>  
**PIPE**<sup>50</sup>

**URBAN CONCRETE**<sup>56</sup>

**VINYL**<sup>66</sup>

Its origin is "underground": Cage is inspired by the lamps used by miners and workers, protected by a metal cage which here becomes a decorative element and gives the lamp its name.

La sua origine è "underground": Cage si ispira alle lampade dei minatori e degli operai, protette da una gabbia metallica, che diventa qui elemento decorativo e dà il nome alla lampada.

# CAGE

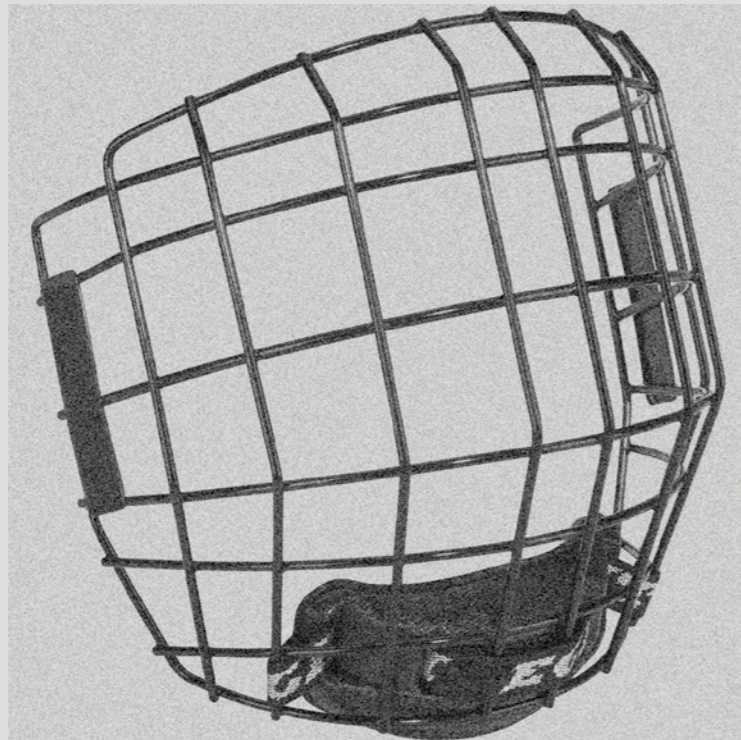
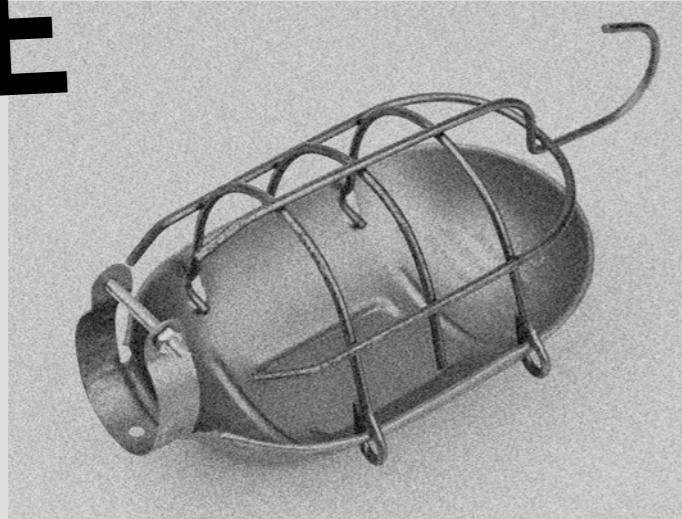

Cage Small, Round Cluster System, composition of 24 lights,  
Black/Bronze

# CAGE

The contrast between the delicacy of the blown glass of the elegant glossy diffuser and the hardness of the steel of the outer cage with its irregular structure makes Cage unique and gives it an elegantly vintage touch. The diffuser is available in two colors, white and bronze, which can be combined as desired with the metal cage in white or black finishes. In the bronze version, the light source gives it a double soul: when switched off, the shiny surface of the glass reflects the geometries of the cage; when switched on, the reflection disappears and the color of the glass becomes warmer. Cage Large, with a diameter of 46 cm, is a suspension lamp of great effect. The Small version, 27.5 cm in diameter, lends itself to multiple compositions with a metropolitan taste.



Il contrasto fra la delicatezza del vetro soffiato dell'elegante diffusore lucido e la durezza dell'acciaio della gabbia esterna dalla struttura irregolare rende Cage inconfondibile e le dona un tocco elegantemente vintage. Il diffusore è disponibile in due colori, white e bronze, che possono essere combinati a piacere con la gabbia metallica nelle finiture white oppure black. Nella versione bronze, la fonte luminosa le regala una doppia anima: da spenta la superficie lucida del vetro riflette le geometrie della gabbia, da accesa il riflesso scompare e il colore del vetro diventa più caldo. Cage Large, con un diametro di 46 cm, è una lampada a sospensione di grande effetto. La versione Small, con i suoi 27,5 cm di diametro, si presta a composizioni multiple dal gusto metropolitano.

Cage Large, White/White



# CAGE

Cage Large, Black/Bronze



# Cage

Cluster Suspension

## Cage Small

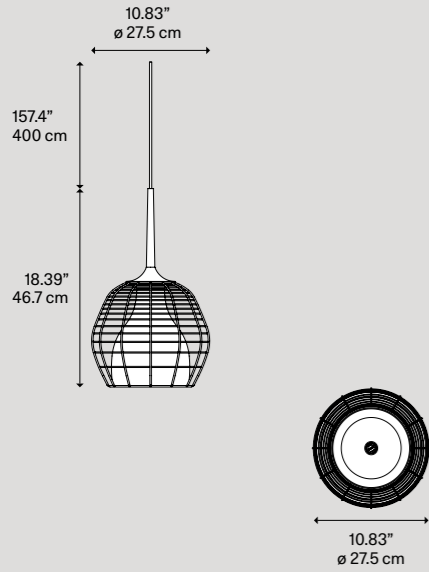

| Light source<br>Sorgente luminosa | Structure<br>Montatura | Diffuser<br>Diffusore | Code<br>Codice | N. America<br>Code |
|-----------------------------------|------------------------|-----------------------|----------------|--------------------|
| LED E27<br>1 max 15W              | White                  | White                 | 501001         | —                  |
|                                   |                        | Bronze                | 501002         | —                  |
|                                   | Black                  | White                 | 501003         | —                  |
|                                   |                        | Bronze                | 501004         | —                  |
| LED<br>Medium Base<br>1 max 15W   | White                  | White                 | —              | 501301             |
|                                   |                        | Bronze                | —              | 501302             |
|                                   | Black                  | White                 | —              | 501303             |
|                                   |                        | Bronze                | —              | 501304             |

BULBS not included  
LAMPADINE non incluse

Net Weight/ Peso Netto: 2.35 kg

Pack/ Colli: 2

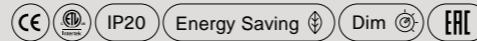

Suspension lamps must be installed on a canopy ► pages 80 - 87  
Le lampade a sospensione devono essere installate su rosone ► pagine 80 - 87



**Materials** Vacuum metallized blown glass diffuser  
Metal cage  
Diffusore in vetro soffiato metallizzato sottovuoto  
Gabbia in metallo

**Light** Suspension lamp shedding diffuse and downward directed light. Commercial light bulb socket  
Lampada a sospensione a luce diffusa e diretta verso il basso. Predisposizione lampadina commerciale.

Suspension

## Cage Large

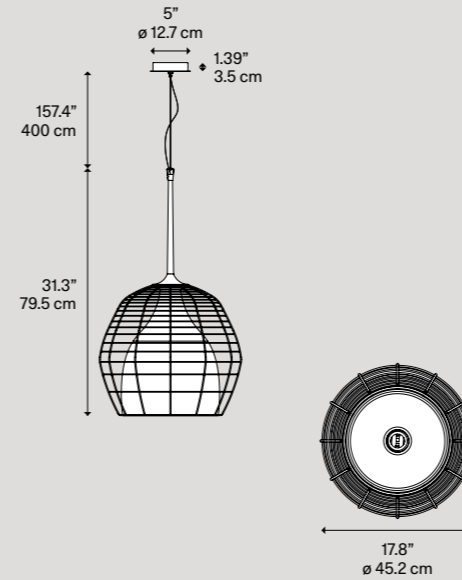

| Light source<br>Sorgente luminosa | Structure<br>Montatura | Diffuser<br>Diffusore | Code<br>Codice | N. America<br>Code |
|-----------------------------------|------------------------|-----------------------|----------------|--------------------|
| LED E27<br>1 max 25W              | White                  | White                 | 501005         | —                  |
|                                   |                        | Bronze                | 501006         | —                  |
|                                   | Black                  | White                 | 501007         | —                  |
|                                   |                        | Bronze                | 501008         | —                  |
| LED<br>Medium Base<br>1 max 25W   | White                  | White                 | —              | 501305             |
|                                   |                        | Bronze                | —              | 501306             |
|                                   | Black                  | White                 | —              | 501307             |
|                                   |                        | Bronze                | —              | 501308             |

BULBS not included  
LAMPADINE non incluse

Net Weight/ Peso Netto: 5.4 kg

Pack/ Colli: 2

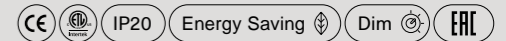

Cage Large, Bronze/Black  
Cage Small, White/White



**Colors** white/ white  
white/ black  
bronze/ white  
bronze/ black





# FLASK

Inspired by the unique shapes of glass bottles used in science labs, Flask features a metallic surface that reveals its glass nature when lit. Its shape recalls an object with an industrial flavor in which the marked contrast between the lightness of blown glass and the material quality of the metal finish are combined. The piece is further enhanced by the contrast between the matt metallic outer and the glossy inner surface that glows and dances with the light.

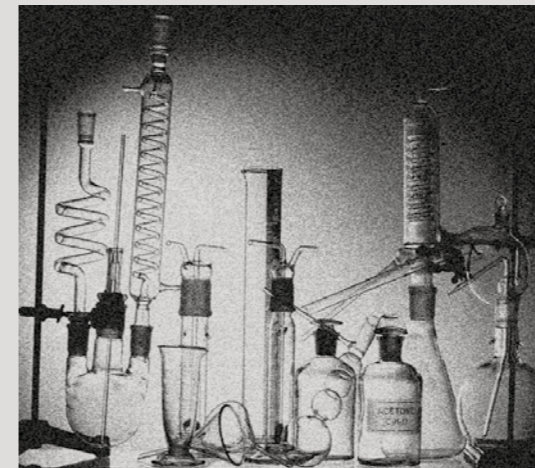

Ispirata alle singolari forme delle bottiglie di vetro utilizzate nei laboratori scientifici, Flask è caratterizzata da una superficie metallica che, una volta accesa, rivela la sua vera natura di vetro.

La sua forma ricorda un oggetto dal sapore industriale in cui il forte contrasto visivo tra la leggerezza del vetro soffiato e la matericità della finitura metallica convivono. La lampada è ulteriormente valorizzata dalla contrapposizione tra la superficie esterna metallizzata opaca e l'interno lucido che, quando la lampada è accesa, si illumina con una inaspettata danza di luce.

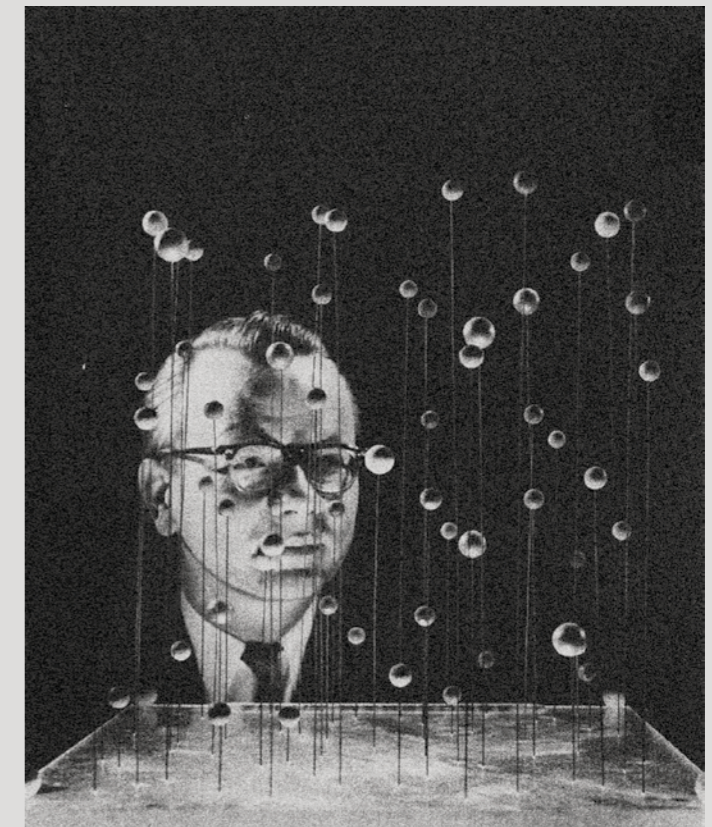



Flask A, B, C  
Metallic Black



## FLASK

When the lamp is lit, Flask reveals a light source that floats in the glass body with an inner glossy surface that glows to create a daring visual effect. The neck of the lamp has been designed to remain dark at all times, thus enhancing the silhouette of the piece and its industrial surface. At the top end, a black silicone cap with the DIESEL logo seals the lamp and gives it an extremely industrial touch.

Available in three shapes and with two finishes – metallic black and mineral sand – that evoke industrial worlds, Flask is a decorative piece that also lends itself to cluster compositions to create vibrant light installations with an extremely contemporary effect.

Accesa, la sospensione Flask rivela una sorgente luminosa che sembra fluttuare nel corpo di vetro, illumina la superficie interna lucida e crea un audace effetto visivo. Il collo della lampada è stato invece progettato per rimanere sempre spento, valorizzando così la linea del prodotto e la sua superficie industriale. All'estremità superiore, un tappo in silicone nero con logo DIESEL sigilla la lampada e le conferisce un tocco estremamente industriale.

Con tre forme disponibili e due finiture che evocano mondi industriali – metallic black e mineral sand – Flask è un pezzo decorativo che si presta anche a composizioni su cluster per creare vibranti installazioni di luce dall'effetto estremamente contemporaneo.

Flask A,B,C, Round Cluster System,  
composition of 14 lights. Metallic black

# FLASK

Flask A,B,C, composition on single mini canopies.  
Round Cluster System, compositions of 3 and 5 lights,  
Metallic black, Mineral sand



Flask A,B,C  
Metallic black, Mineral sand

# FLASK



# Flask

Cluster Suspension

## Flask A

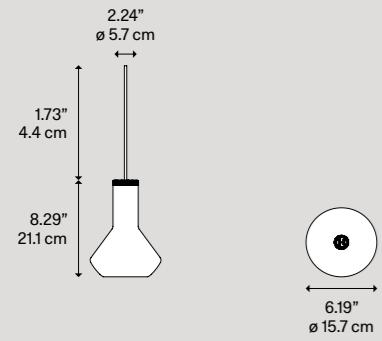

| Light source<br>Sorgente luminosa | Structure<br>Montatura | Diffuser<br>Diffusore | Code<br>Codice | N. America<br>Code |
|-----------------------------------|------------------------|-----------------------|----------------|--------------------|
| LED E27<br>1 max 15W              | —                      | Metallic black        | 503001         | —                  |
|                                   |                        | Mineral sand          | 503002         | —                  |
| LED<br>Medium Base<br>1 max 15W   | —                      | Metallic black        | —              | 503301             |
|                                   |                        | Mineral sand          | —              | 503302             |

BULBS not included  
LAMPADINE non incluse

Net Weight/ Peso Netto: 0.44 kg

Pack/ Colli: 2

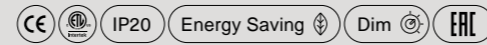

Suspension lamps must be installed on a canopy ► pages 80 - 87  
Le lampade a sospensione devono essere installate su rosone ► pagine 80 - 87

Cluster Suspension

## Flask C

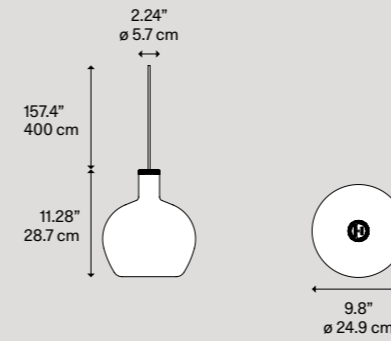

| Light source<br>Sorgente luminosa | Structure<br>Montatura | Diffuser<br>Diffusore | Code<br>Codice | N. America<br>Code |
|-----------------------------------|------------------------|-----------------------|----------------|--------------------|
| LED E27<br>1 max 15W              | —                      | Metallic black        | 503005         | —                  |
|                                   |                        | Mineral sand          | 503006         | —                  |
| LED<br>Medium Base<br>1 max 15W   | —                      | Metallic black        | —              | 503305             |
|                                   |                        | Mineral sand          | —              | 503306             |

BULBS not included  
LAMPADINE non incluse

Net Weight/ Peso Netto: 0.75 kg

Pack/ Colli: 2

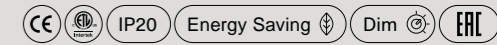

Suspension lamps must be installed on a canopy ► pages 80 - 87  
Le lampade a sospensione devono essere installate su rosone ► pagine 80 - 87

Cluster Suspension

## Flask B

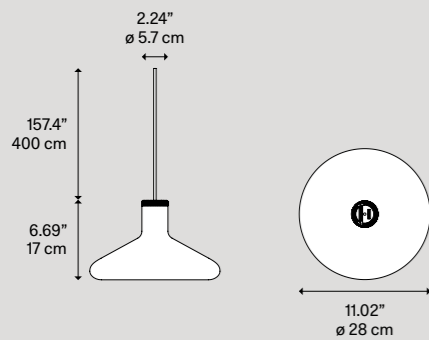

| Light source<br>Sorgente luminosa | Structure<br>Montatura | Diffuser<br>Diffusore | Code<br>Codice | N. America<br>Code |
|-----------------------------------|------------------------|-----------------------|----------------|--------------------|
| LED E27<br>1 max 15W              | —                      | Metallic black        | 503003         | —                  |
|                                   |                        | Mineral sand          | 503004         | —                  |
| LED<br>Medium Base<br>1 max 15W   | —                      | Metallic black        | —              | 503303             |
|                                   |                        | Mineral sand          | —              | 503304             |

BULBS not included  
LAMPADINE non incluse

Net Weight/ Peso Netto: 0.95 kg

Pack/ Colli: 2

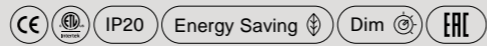

Suspension lamps must be installed on a canopy ► pages 80 - 87  
Le lampade a sospensione devono essere installate su rosone ► pagine 80 - 87

**Materials** Vacuum metallized blown glass diffuser  
Diffusore in vetro soffiato metallizzato sottovuoto

**Light** Suspension lamp providing direct light  
commercial light bulb socket  
Lampada a sospensione a luce diretta  
Predisposizione lampadine commerciali

**Colors** Metallic black  
Mineral sand



Flask, black cap with the Diesel logo

Flask, Mineral sand



# FORK

Fork is a steel "fork" holding a diffuser inspired by casual fashion, camping tents and an informal and gritty lifestyle. An always current concept interpreted in table, floor and suspension versions, for every environment and moment of everyday life.

Fork è una "forchetta" di acciaio su cui posa un diffusore ispirato alla moda casual, alle tende da campeggio, a uno stile di vita informale e grintoso. Un concetto sempre attuale declinato nelle versioni da tavolo, terra e sospensione, per ogni ambiente e momento della vita quotidiana.

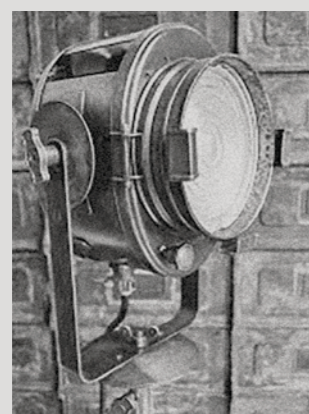



# FORK

Just like when you turn on a lamp inside a camping tent, the light inside the diffuser highlights the patchwork structure and enhances the texture of the canvas with visible stitching as in jeans. The linen cotton diffuser, available in ivory and gray, creates a warm and soft lighting effect. 360° adjustable thanks to the gunmetal colored brass eyelets in strong material contrast with the softness of the fabric, the diffuser allows the light beam to be directed at will.

Fork Small, Round Cluster System,  
composition of 7 lights,  
Ivory/Ivory and Anthracite/Gray



Come quando si accende una lampada dentro a una tenda da campeggio, la luce all'interno del diffusore evidenzia la struttura a patchwork ed esalta la texture della tela con le cuciture a vista come nei jeans. Il diffusore in cotone-lino, disponibile in ivory e gray, crea un effetto luminoso caldo e soffuso. Orientabile a 360° grazie agli occhielli in ottone color canna di fucile in forte contrasto materico con la morbidezza del tessuto, il diffusore permette di dirigere il fascio di luce a piacere.

## FLOOR FORK

The metal structure supporting the diffuser is available in two colors, ivory or anthracite. The rod, with its characteristic tilt, swivels on the base, allowing the light to be projected in complete freedom.

La struttura in metallo che regge il diffusore è disponibile in color ivory o anthracite. L'asta, con l'inclinazione che da sempre la caratterizza, gira sulla base e permette di condividere il fascio di luce in assoluta libertà.

## TABLE FORK

The metal structure proposes the same lines, colors and functions of the floor lamp but in a Small version, perfect for any space.

La struttura in metallo ripropone linee, colori e funzioni della lampada da terra ma in versione Small, perfetta per qualunque spazio.

## SUSPENSION FORK

In the Large version, Fork is a single suspension lamp with great character thanks to the adjustable diffuser suspended from a supporting cable. The Small version gives its best in multiple canopy compositions, with diffusers that scrutinize the space creating lively plays of light.

In versione Large, Fork è una sospensione singola di grande carattere grazie al diffusore orientabile sospeso ad un cavo portante. La versione Small dà il meglio di sé in composizioni su rosone multiplo, con i diffusori che scrutano lo spazio con vivaci giochi di fasci luminosi.

# FORK

Fork table, floor, suspension  
Anthracite/Ivory





# Fork

Cluster Suspension

## Fork Small

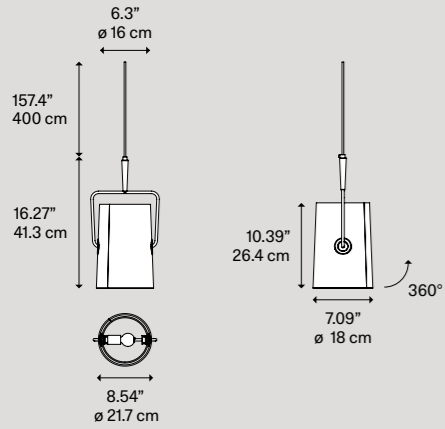

| Light source<br>Sorgente luminosa                       | Structure<br>Montatura | Diffuser<br>Diffusore | Code<br>Codice | N. America<br>Code |
|---|------------------------|-----------------------|----------------|--------------------|
| LED E14<br>1 max 15W<br>(L Max 90 mm)                   | Ivory                  | Ivory                 | 505001         | —                  |
|   | Anthracite             | Gray                  | 505002         | —                  |
|   | Anthracite             | Ivory                 | 505003         | —                  |
|   | Anthracite             | Gray                  | 505004         | —                  |
| LED<br>Candelabra<br>Base<br>1 max 15W<br>(L Max 3.54") | Ivory                  | Ivory                 | —              | 505301             |
|   | Anthracite             | Gray                  | —              | 505302             |
|   | Anthracite             | Ivory                 | —              | 505303             |
|   | Anthracite             | Gray                  | —              | 505304             |

BULBS not included  
LAMPADINE non incluse

Net Weight/ Peso Netto: 0.8 kg

Pack/ Colli: 2

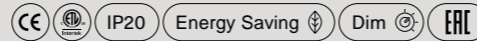

Suspension

## Fork Large

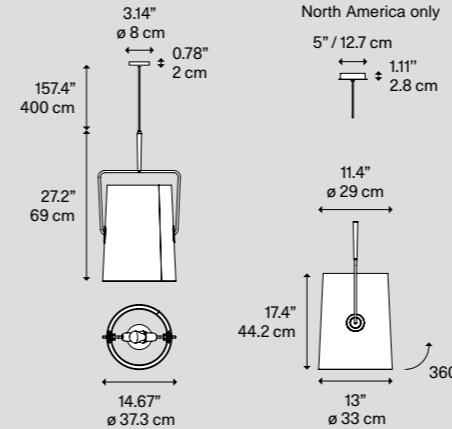

| Light source<br>Sorgente luminosa                | Structure<br>Montatura | Diffuser<br>Diffusore | Code<br>Codice | N. America<br>Code |
|--|------------------------|-----------------------|----------------|--------------------|
| LED E27<br>2 max 25W<br>(Max Ø 65 mm)            | Ivory                  | Ivory                 | 505005         | —                  |
|  | Anthracite             | Gray                  | 505006         | —                  |
|  | Anthracite             | Ivory                 | 505007         | —                  |
|  | Anthracite             | Gray                  | 505008         | —                  |
| LED<br>Medium Base<br>2 max 25W<br>(Max Ø 2.56") | Ivory                  | Ivory                 | —              | 505305             |
|  | Anthracite             | Gray                  | —              | 505306             |
|  | Anthracite             | Ivory                 | —              | 505307             |
|  | Anthracite             | Gray                  | —              | 505308             |

BULBS not included  
LAMPADINE non incluse

Net Weight/ Peso Netto: 1.92 kg

Pack/ Colli: 2

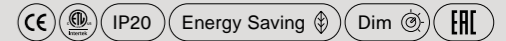

Suspension lamps must be installed on a canopy ► pages 80 - 87  
Le lampade a sospensione devono essere installate su rosone ► pagine 80 - 87



Fork Small, Ivory/Ivory and Anthracite/Gray  
Fork Large, Anthracite/Ivory



**Materials**  
Cotton-linen diffuser  
Metal structure  
Diffusore in lino-cotone  
Struttura in metallo

**Light**  
Lamp providing direct and diffused light  
Two commercial light bulb sockets in the Large  
diffuser and one light bulb socket in the Small diffuser  
Lampada a luce diretta e diffusa  
Predisposizione per due lampadine commerciali nel  
diffusore Large e una lampadina nel diffusore Small

**Colors**  
Ivory / ivory  
Ivory / anthracite  
Gray / ivory  
Gray / anthracite

# Fork

Floor

## Fork

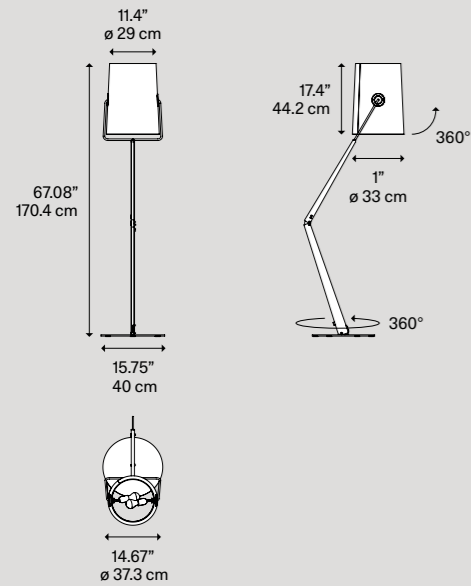

| Light source<br>Sorgente luminosa                | Structure<br>Montatura | Diffuser<br>Diffusore | Code<br>Codice | N. America<br>Code |
|--|------------------------|-----------------------|----------------|--------------------|
| LED E27<br>2 max 25W<br>(Max Ø 65 mm)            | Ivory                  | Ivory                 | 505013         | —                  |
|  |                        | Gray                  | 505014         | —                  |
|  | Anthracite             | Ivory                 | 505015         | —                  |
|  |                        | Gray                  | 505016         | —                  |
| LED<br>Medium Base<br>2 max 25W<br>(Max Ø 2.56") | Ivory                  | Ivory                 | —              | 505313             |
|  |                        | Gray                  | —              | 505314             |
|  | Anthracite             | Ivory                 | —              | 505315             |
|  |                        | Gray                  | —              | 505316             |

BULBS not included  
LAMPADINE non incluse

Net Weight/ Peso Netto: 11.82 kg

Pack/ Colli: 2

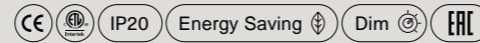

Table

## Fork

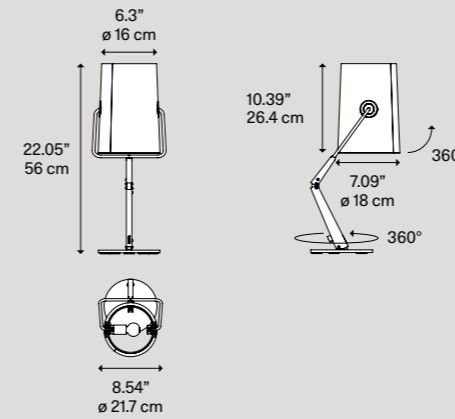

| Light source<br>Sorgente luminosa                       | Structure<br>Montatura | Diffuser<br>Diffusore | Code<br>Codice | N. America<br>Code |
|---|------------------------|-----------------------|----------------|--------------------|
| LED E14<br>1 max 15W<br>(L Max 90 mm)                   | Ivory                  | Ivory                 | 505009         | —                  |
|   |                        | Gray                  | 505010         | —                  |
|   | Anthracite             | Ivory                 | 505011         | —                  |
|   |                        | Gray                  | 505012         | —                  |
| LED<br>Candelabra<br>Base<br>1 max 15W<br>(L Max 3.54") | Ivory                  | Ivory                 | —              | 505309             |
|   |                        | Gray                  | —              | 505310             |
|   | Anthracite             | Ivory                 | —              | 505311             |
|   |                        | Gray                  | —              | 505312             |

BULBS not included  
LAMPADINE non incluse

Net Weight/ Peso Netto: 2.85 kg

Pack/ Colli: 2

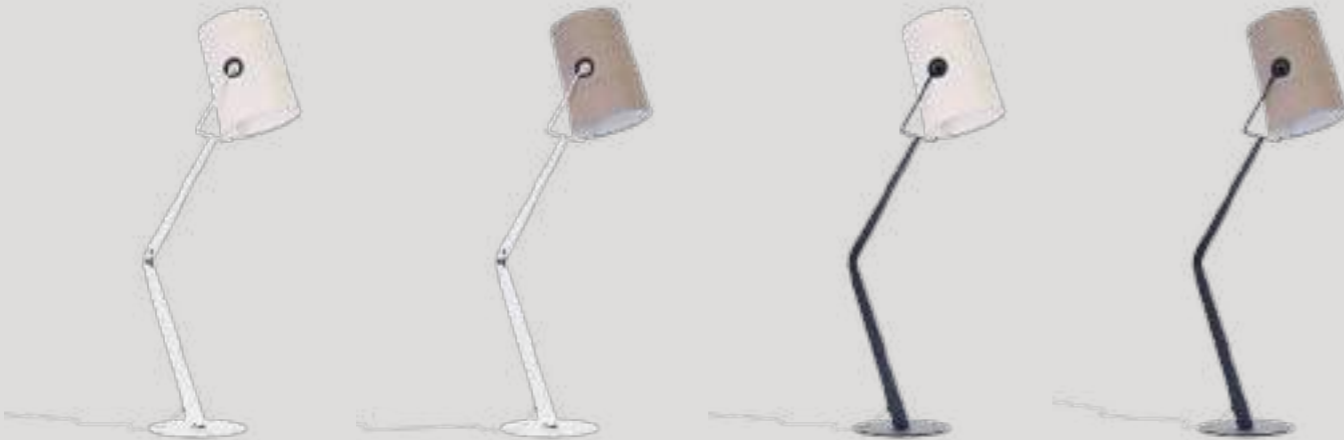
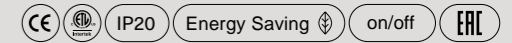

**Materials** Cotton-linen diffuser  
Metal structure  
Diffusore in lino-cotone  
Struttura in metallo

**Light** Lamp providing direct and diffused light  
Two commercial light bulb sockets in the Large diffuser  
and one light bulb socket in the Small diffuser  
Lampada a luce diretta e diffusa  
Predisposizione per due lampadine commerciale nel  
diffusore Large e una lampadina nel diffusore Small

**Colors** Ivory / ivory      Gray / ivory  
Ivory / anthracite      Gray / anthracite

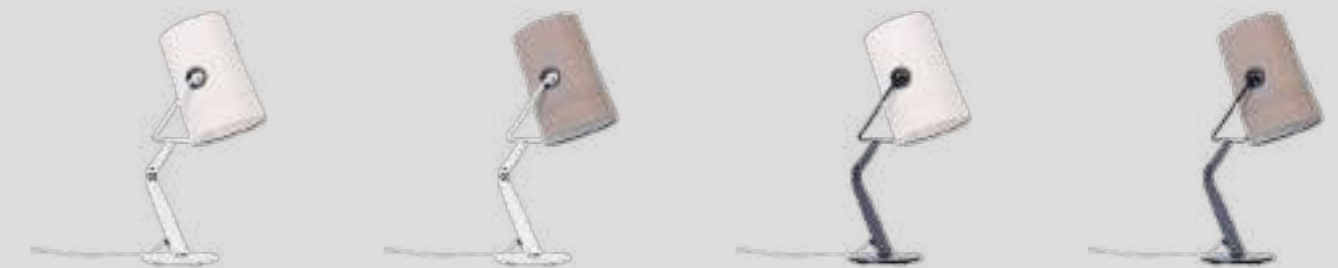

**Materials** Cotton-linen diffuser  
Metal structure  
Diffusore in lino-cotone  
Struttura in metallo

**Light** Lamp providing direct and diffused light  
Two commercial light bulb sockets in the Large diffuser  
and one light bulb socket in the Small diffuser  
Lampada a luce diretta e diffusa  
Predisposizione per due lampadine commerciali nel  
diffusore Large e una lampadina nel diffusore Small

**Colors** Ivory / ivory      Gray / ivory  
Ivory / anthracite      Gray / anthracite



# GASK

Gask is a small suspension lamp with a big presence. It looks like it came out of a 1920s emporium or a warehouse for work tools, but also recalls ziggurats, the sacred terraced pyramids of ancient Mesopotamia.

Gask è una piccola lampada a sospensione dalla grande presenza. Sembra uscita da un emporio degli anni Venti o da un magazzino di strumenti di lavoro, ma ricorda anche le ziggurat, sacre piramidi a terrazze dell'antica Mesopotamia.

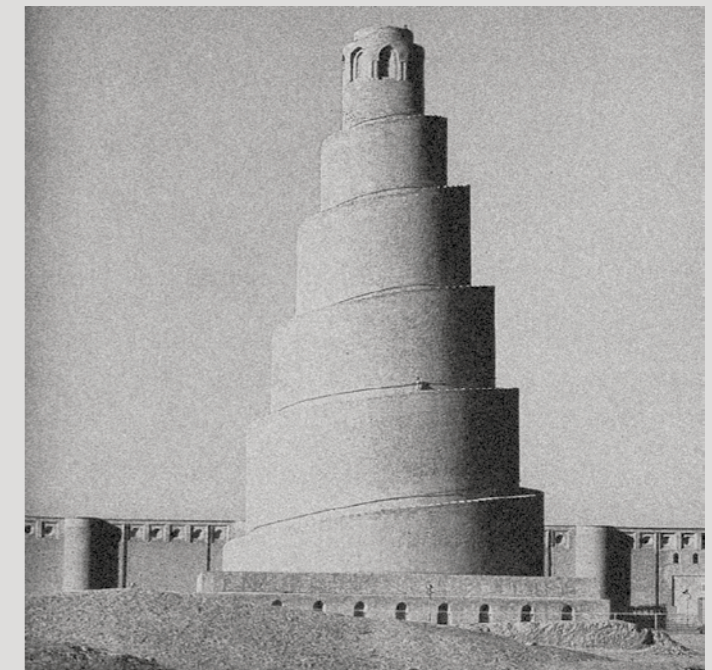

Gask, Transparent



Gask è un mix perfetto di materiali in apparente contrasto sensoriale - vetro, acciaio, ottone - che creano una miscela ideale. La montatura in acciaio ha una finitura nera opaca, ruvida e materica dal sapore fortemente industriale, ed è unita al diffusore con bulloni a vista in ottone. Il delicato diffusore in vetro soffiato, nelle finiture transparent o army green, dichiara deliberatamente la presenza della fonte luminosa al suo interno.

Gask è una lampada impattante sia singolarmente che in composizioni multiple su rosone, anche intercalando le due diverse finiture in un gioco di trasparenze e opacità. Con il suo sapore retrò che incontra il senso pratico della modernità, Gask combina perfettamente i richiami al passato e lo stile di vita contemporaneo.

# GASK

Gask is a perfect mix of materials in apparent sensory contrast - glass, steel, brass - which create an ideal blend. The steel mount has a black matt finish, rough and textured with a strong industrial flavor, and is joined to the diffuser with visible brass bolts. The subtle diffuser in blown glass, in transparent or army green finishes, intentionally declares the presence of the light source inside.

Gask is a lamp with an impact, both individually and in multiple canopy compositions, also by interspersing the two different finishes in a play of transparencies and opacity. With its retro flavor that meets the practical sense of modernity, Gask perfectly combines references to the past and contemporary living.



Gask, Army green

# GASK

Gask, Rectangular and Round Cluster System,  
compositions of 14 lights,  
Army green, Transparent



# Gask

Cluster Suspension

## Gask

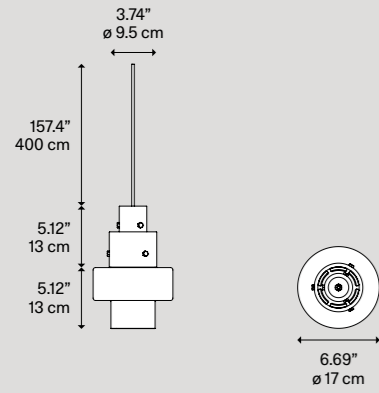

Net Weight/ Peso Netto: 3.77 kg

Pack/ Colli: 2

| Light source<br>Sorgente luminosa      | Structure<br>Montatura | Diffuser<br>Diffusore | Code<br>Codice | N. America<br>Code |
|--|------------------------|-----------------------|----------------|--------------------|
| LED E14<br>1 max 15W                   | Black                  | Transparent           | 506001         | —                  |
|  |                        | Army green            | 506002         | —                  |
| LED<br>Candelabra<br>Base<br>1 max 15W | Black                  | Transparent           | —              | 506301             |
|  |                        | Army green            | —              | 506302             |

BULBS not included  
LAMPADINE non incluse



Suspension lamps must be installed on a canopy ► pages 80 - 87  
Le lampade a sospensione devono essere installate su rosone ► pagine 80 - 87



**Materials** Blown glass diffuser  
Metal structure  
Diffusore in vetro soffiato  
Struttura in metallo

**Colors** Transparent  
Army green

**Light** Suspension lamp providing direct and diffused light  
commercial light bulb socket  
Lampada a luce diretta e diffusa  
Predisposizione lampadina commerciale

Gask, Round Cluster System, composition of 5 lights,  
Transparent, Army green



Like a drop of incandescent material, Glass Drop seems to represent the magical and elusive nature of blown glass at the instant it is both fluid and solid, just before it takes shape.

Come una goccia di materiale incandescente, Glass Drop sembra rappresentare la magica e sfuggente natura del vetro soffiato nell'istante in cui è al tempo stesso fluido e solido, poco prima di prendere forma.

# GLASS DROP

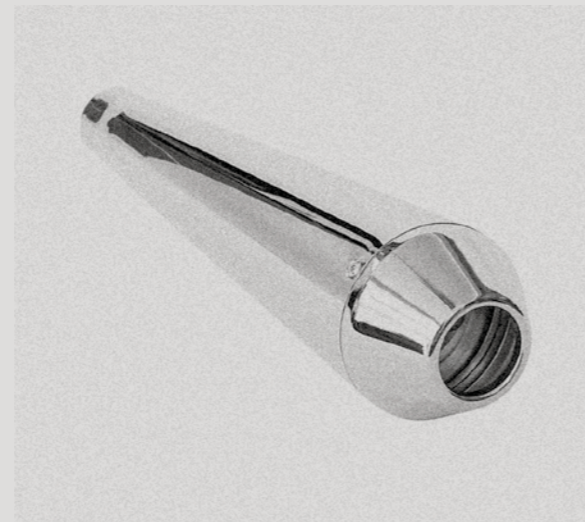
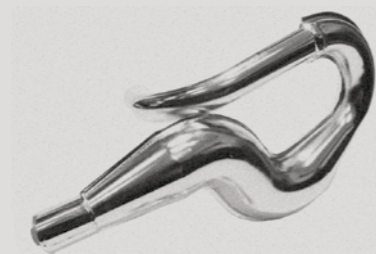
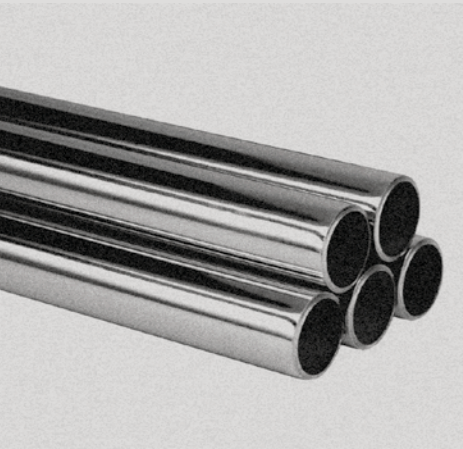

Glass Drop, Chrome



Nella versione chrome, ha una superficie che da spenta riflette come uno specchio, mentre da accesa sembra che la luce sciogla il metallo rivelando il proprio colore: una lampada che cambia personalità con un semplice tocco sull'interruttore. Glass Drop è disponibile anche in una candida versione white che offre un'estrema versatilità di ambientazione.

Glass Drop è particolarmente d'effetto in composizioni multiple, come un gioiello composto da tanti pendenti che coniuga funzionalità e armonia del segno.

## GLASS DROP

In the chrome version, its surface reflects like a mirror when turned off, while when turned on the light seems to dissolve the metal revealing its color: a lamp that changes personality with a simple touch of the switch.

Glass Drop is also available in a pure white version that offers extreme versatility of setting.

Glass Drop is particularly striking in multiple compositions, like a piece of jewelry consisting of many pendants that combines functionality and design harmony.

Glass Drop, Chrome >





# GLASS DROP

Glass Drop, Chrome



# Glass Drop

Cluster Suspension

## Glass Drop

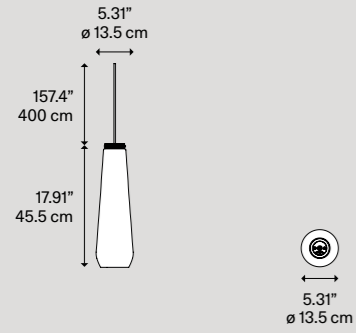

| Light source<br>Sorgente luminosa | Structure<br>Montatura | Diffuser<br>Diffusore | Code<br>Codice | N. America<br>Code |
|-----------------------------------|------------------------|-----------------------|----------------|--------------------|
| LED E27<br>1 max 25W              | —                      | White                 | 504001         | —                  |
|                                   |                        | Chrome                | 504002         | —                  |
| LED<br>Medium Base<br>1 max 25W   | —                      | White                 | —              | 504301             |
|                                   |                        | Chrome                | —              | 504302             |

BULBS not included  
LAMPADINE non incluse

Net Weight/ Peso Netto: 1.77 kg

Pack/ Colli: 2

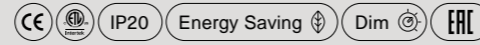

Suspension lamps must be installed on a canopy ► pages 80 - 87  
Le lampade a sospensione devono essere installate su rosone ► pagine 80 - 87



**Materials** Blown glass diffuser  
Diffusore in vetro soffiato

**Colors** White  
Chrome

**Light** Suspension lamp providing diffused light  
commercial light bulb socket  
Lampada a sospensione a luce diffusa  
Predisposizione lampadine commerciali

Glass Drop,  
White, Chrome





Shapes reminiscent of large factory pipes, dematerialized and lightened by their fabric nature. These are the Pipe lamps, which stand out due to their large size and the warm light diffused over the entire surface.

Forme che ricordano le grandi tubature di una fabbrica, smaterializzate e alleggerite dalla loro natura tessile. Sono le lampade Pipe, che si caratterizzano per le dimensioni importanti e la luce calda diffusa su tutta la superficie.

# PIPE

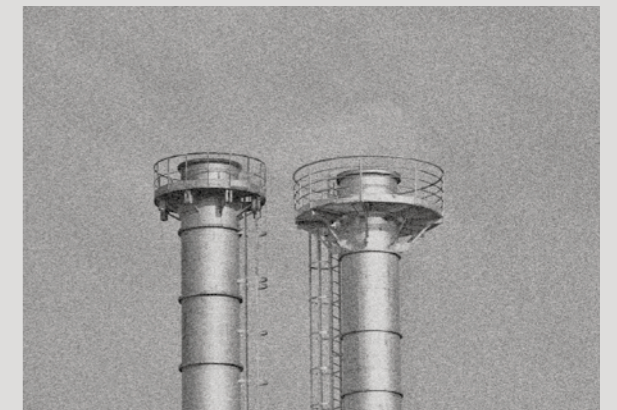

# PIPE

Pipe was born from Diesel's research in the world of fabrics and is available in bleached raw linen or with printed patterns. The irregular weave transforms into a luminous décor, adding further emotion to the fabric and revolutionizing the traditional lampshade.

Available in two sizes, Medium and Large, Pipe is an architectural presence that can be used alone or in groups of several elements, to illuminate, characterize and even define a space.

Pipe Large, White



Pipe nasce dalla ricerca Diesel nell'universo dei tessuti ed è disponibile in lino grezzo sbiancato o con decoro stampato. La trama irregolare si trasforma in un decoro luminoso, aggiungendo ulteriore emozione al tessuto e rivoluzionando il paralume tradizionale.

Disponibile in due dimensioni, Medium e Large, Pipe è una presenza architettonica che può essere utilizzata da sola o in gruppi di più elementi, per illuminare, caratterizzare e anche definire uno spazio.

Pipe Medium and Large, Black >



# Pipe

Floor

## Pipe Medium

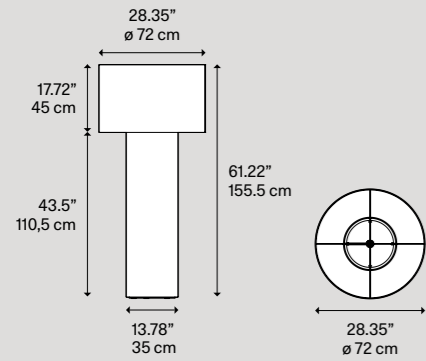

| Light source<br>Sorgente luminosa | Structure<br>Montatura | Diffuser<br>Diffusore | Code<br>Codice | N. America<br>Code |
|-----------------------------------|------------------------|-----------------------|----------------|--------------------|
| LED E27<br>2 max 25W              | —                      | White                 | 507001         | —                  |
|                                   |                        | Black                 | 507002         | —                  |
| LED<br>Medium Base<br>2 max 25W   | —                      | White                 | —              | 507301             |
|                                   |                        | Black                 | —              | 507302             |

BULBS not included  
LAMPADINE non incluse

Net Weight/ Peso Netto: 9 kg Pack/ Colli: 3

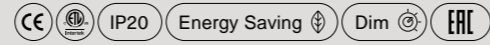

Floor

## Pipe Large

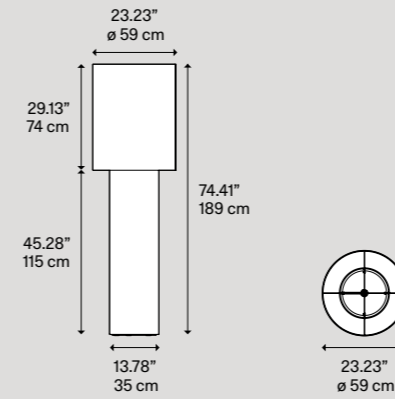

| Light source<br>Sorgente luminosa | Structure<br>Montatura | Diffuser<br>Diffusore | Code<br>Codice | N. America<br>Code |
|-----------------------------------|------------------------|-----------------------|----------------|--------------------|
| LED E27<br>2 max 25W              | —                      | White                 | 507003         | —                  |
|                                   |                        | Black                 | 507004         | —                  |
| LED<br>Medium Base<br>2 max 25W   | —                      | White                 | —              | 507303             |
|                                   |                        | Black                 | —              | 507304             |

BULBS not included  
LAMPADINE non incluse

Net Weight/ Peso Netto: 8.5 kg Pack/ Colli: 3



**Materials** Linen diffuser  
Diffusore in lino

**Colors** White  
Black

**Light** Lamp providing diffused light  
Two commercial light bulb sockets  
Lampada a luce diffusa  
Predisposizione per due lampadine commerciali



Pipe Medium, White



Taking inspiration from the bollards found in the urban landscape, Urban Concrete is a lighting piece balancing clean lines and solid surfaces with a dome crowned by a lifting hook.

Ispirata ai dissuasori che emergono dal paesaggio urbano, Urban Concrete è una lampada che coniuga linee pulite e superfici solide in una forma a cupola sormontata da un gancio di sollevamento.

# URBAN CONCRETE

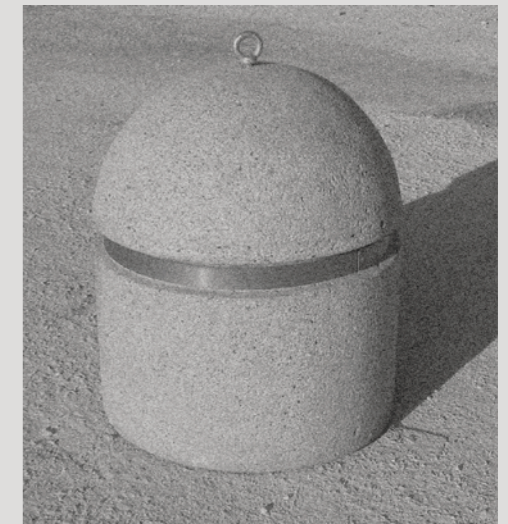
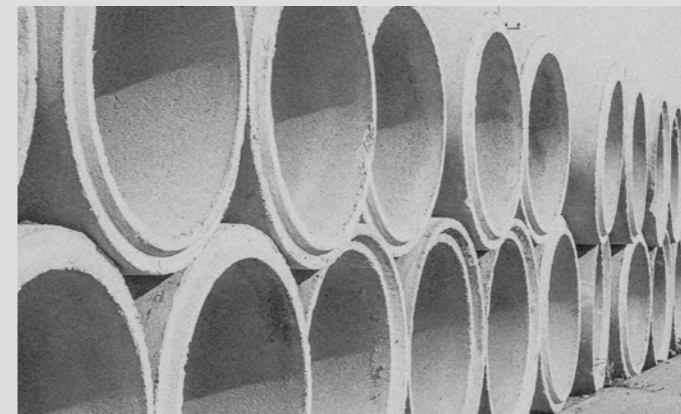
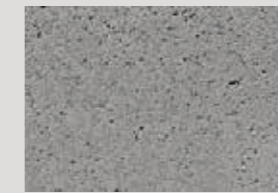

Urban Concrete 25, Round Cluster System, composition of 36 lights,  
Pink dust, Tough gray, Soft gray

# URBAN CONCRETE

Whilst the spun metal dome evokes a cement block and creates an illusion of heaviness, Urban Concrete is extremely light and flexible. Thanks to the contrast between the three cement finishes – soft gray, tough gray and pink dust – and the pure white of the diffuser's internal surface, Urban Concrete gives a touch of material appeal and sophistication to any interior.

Available in four sizes (25, 50, 60, and 80 cm), Urban Concrete is designed for different uses and interiors, both domestic and public. The 25 cm dome is suspended from one single power cable and can also be installed on multiple canopies to create pop compositions and unique clusters through a dynamic interplay between solidity and simplicity.

Urban Concrete 50, Tough gray



Mentre la cupola in metallo tornito richiama un blocco di cemento e crea un'illusione di gravità, Urban Concrete è in realtà una lampada a sospensione molto leggera e duttile. Grazie al contrasto tra le tre finiture in cemento – soft gray, tough gray e pink dust – e il bianco candido della superficie interna del diffusore, Urban Concrete conferisce un tocco di matericità e raffinatezza a qualsiasi interno.

Disponibile in quattro dimensioni (25, 50, 60 e 80 cm), Urban Concrete è pensata per diversi usi e tipologie di interni domestici e pubblici. La cupola da 25 cm è sospesa ad un singolo cavo portante e può essere installata anche su rosoni multipli per creare composizioni pop e cluster unici, con un gioco di equilibri tra solidità e semplicità.



# URBAN CONCRETE

Urban Concrete 80, Soft gray  
Urban Concrete 25, Round Cluster System, compositions of 3 lights,  
Pink dust, Soft gray, Tough gray





# Urban Concrete

Cluster/ Suspension

## Urban Concrete 25

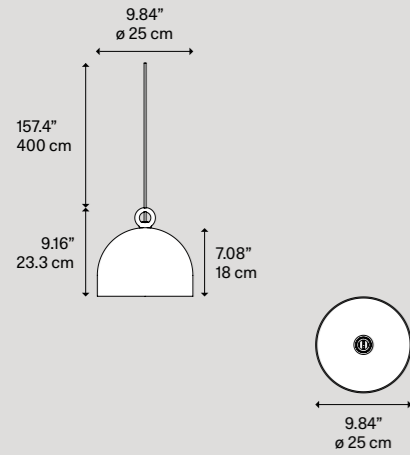

| Light source<br>Sorgente luminosa           | Inside diffuser<br>Diffusore interno | Outside diffuser<br>Diffusore esterno | Code<br>Codice | N. America<br>Code |
|---|--------------------------------------|---------------------------------------|----------------|--------------------|
| LED E27<br>1 max 25W                        | White                                | Pink dust                             | 502001         | —                  |
|   |                                      | Tough gray                            | 502002         | —                  |
|   |                                      | Soft gray                             | 502003         | —                  |
| LED<br>Medium Base<br>1 max 25W             | White                                | Pink dust                             | —              | 502301             |
|   |                                      | Tough gray                            | —              | 502302             |
|   |                                      | Soft gray                             | —              | 502303             |
| BULBS not included<br>LAMPADINE non incluse |                                      |                                       |                |                    |

Net Weight/ Peso Netto: 1.45 kg

Pack/ Colli: 1

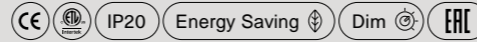

Suspension lamps must be installed on a canopy ► pages 80 - 87  
Le lampade a sospensione devono essere installate su rosone ► pagine 80 - 87



**Materials** Metal diffuser  
Diffusore in metallo

**Colors** Pink dust  
Tough gray  
Soft gray

**Light** Suspension lamp providing direct light  
Lampada a sospensione a luce diretta

Urban Concrete 25,  
Pink dust, Soft gray, Tough gray



# Urban Concrete

Suspension

## Urban Concrete 50

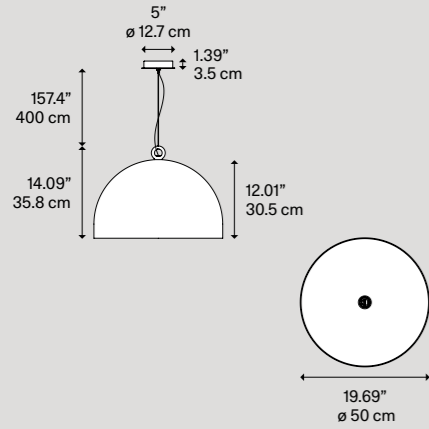

Light source  
Sorgente luminosa

Inside diffuser  
Diffusore interno

Outside diffuser  
Diffusore esterno

Code  
Codice

N. America  
Code

LED E27 G95  
1 max 25W



White



Pink dust

502004

—



Tough gray

502005

—



Soft gray

502006

—

LED G30  
Medium Base  
1 max 25W



White



Pink dust

—

502304



Tough gray

—

502305



Soft gray

—

502306

BULBS not included  
LAMPADINE non incluse

Net Weight/ Peso Netto: 5.5 kg

Pack/ Colli: 1

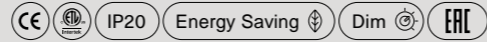

Urban Concrete 50



Urban Concrete 60



Urban Concrete 80



Suspension

## Urban Concrete 60

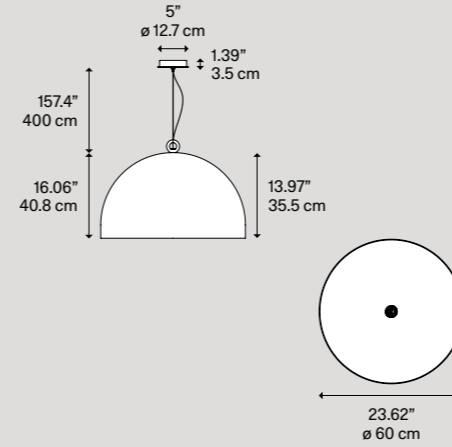

Light source  
Sorgente luminosa

Inside diffuser  
Diffusore interno

Outside diffuser  
Diffusore esterno

Code  
Codice

N. America  
Code

LED E27 G95  
1 max 25W



White



Pink dust

502007

—



Tough gray

502008

—



Soft gray

502009

—

LED G30  
Medium Base  
1 max 25W



White



Pink dust

—

502307



Tough gray

—

502308



Soft gray

—

502309

BULBS not included  
LAMPADINE non incluse

Net Weight/ Peso Netto: 9 kg

Pack/ Colli: 1

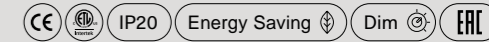

Suspension

## Urban Concrete 80

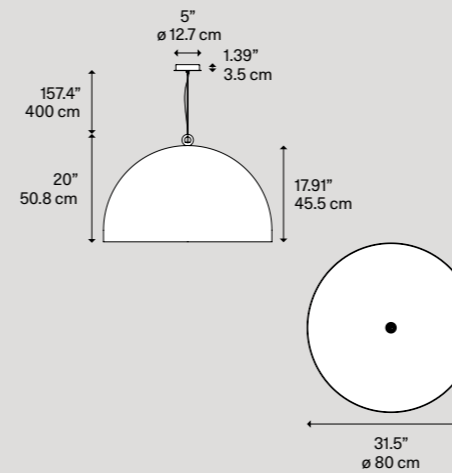

Light source  
Sorgente luminosa

Inside diffuser  
Diffusore interno

Outside diffuser  
Diffusore esterno

Code  
Codice

N. America  
Code

LED E27 G95  
1 max 25W



White



Pink dust

502010

—



Tough gray

502011

—



Soft gray

502012

—

LED G30  
Medium Base  
1 max 25W



White



Pink dust

—

502310



Tough gray

—

502311



Soft gray

—

502312

BULBS not included  
LAMPADINE non incluse

Net Weight/ Peso Netto: 15.5 kg

Pack/ Colli: 1

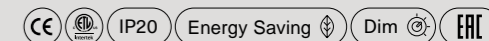

An extremely graphic lamp, Vinyl is made up of a metal plate with a circular engraved texture reminiscent of a music record, emulating sound vibrations whilst dividing the light in a captivating manner to the human eye.

Lampada estremamente grafica, Vinyl è formata da una superficie metallica con un motivo circolare inciso simile ad un disco in vinile che sembra emulare le vibrazioni sonore mentre scompare la luce in modo accattivante all'occhio umano.

# VINYL

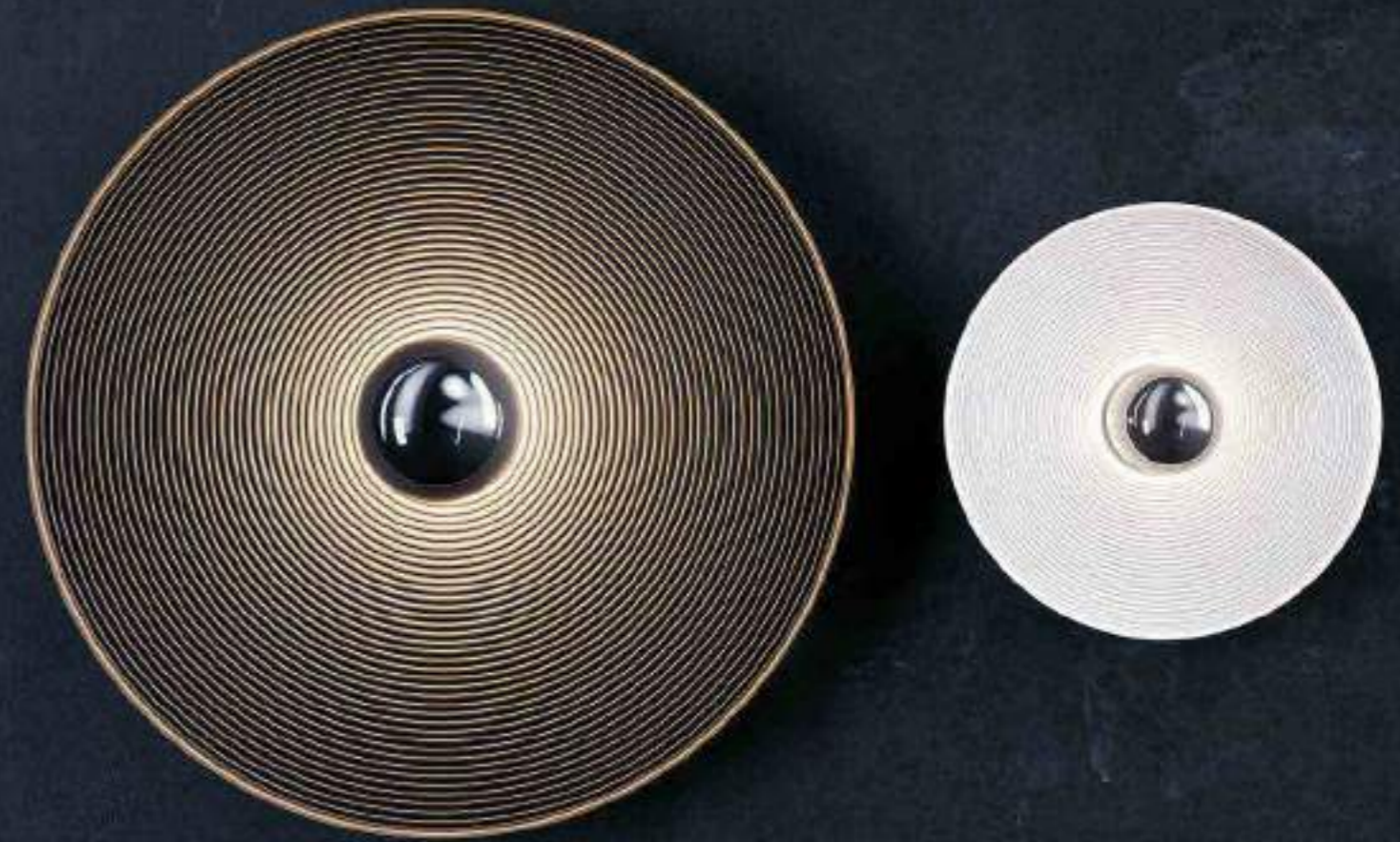
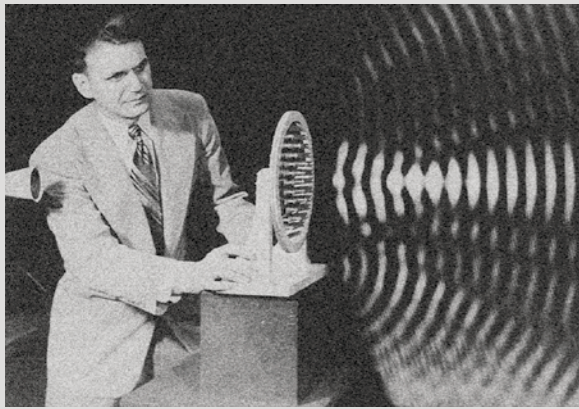

# VINYL

Vinyl is a versatile, spun metal ceiling and wall lamp, but it is also perfect as a suspension lamp. It is available in two sizes, 60 and 32 cm, and two finishes: silver and deep black.

For wall and ceiling versions it is recommended to use shielded light bulbs for an indirect, grazing light effect on the surface, which will seem to vibrate.

Its dynamic design makes this decorative lamp perfect for public spaces. Spin the vinyl and enjoy the light!



Vinyl Large wall, Deep black

Vinyl Large suspension, Deep black



Vinyl è una versatile lampada da soffitto e da parete in metallo tornito, perfetta anche come elemento a sospensione. È disponibile in due dimensioni, 60 e 32 cm di diametro, e due finiture: silver e deep black. Per le varianti a parete e soffitto si consiglia l'utilizzo di lampadine a calotta schermata per un effetto di luce indiretta e radente alla superficie, che sembrerà vibrare.

Il suo segno dinamico rende questa lampada decorativa perfetta per gli spazi pubblici. Fate girare il vinile e godetevi la luce!

# VINYL

Vinyl ceiling and suspension, Deep black, Silver



# VINYL

Vinyl Small and Large,  
wall and suspension, Deep black, Silver



# Vinyl

Suspension

## Vinyl Small

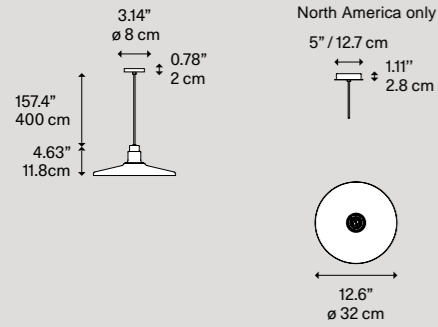

| Light source<br>Sorgente luminosa | Structure<br>Montatura | Diffuser<br>Diffusore | Code<br>Codice | N. America<br>Code |
|-----------------------------------|------------------------|-----------------------|----------------|--------------------|
| LED E27<br>1 max 25W              | Black                  | Silver                | 508005         | —                  |
|                                   |                        | Deep black            | 508006         | —                  |
| LED<br>Medium Base<br>1 max 25W   | Black                  | Silver                | —              | 508305             |
|                                   |                        | Deep black            | —              | 508306             |

BULBS not included  
LAMPADINE non include

Net Weight/ Peso Netto: 1.03 kg

Pack/ Colli: 2

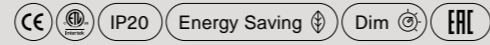

**Materials** Metal diffuser  
Diffusore in metallo

**Colors** Silver  
Deep black

**Light** Lamp providing shielded / indirect / direct light according to the light bulb  
commercial light bulb socket  
Lampada a luce schermata / indiretta / diretta a seconda della lampadina  
Predisposizione lampadine commerciali

Suspension

## Vinyl Large

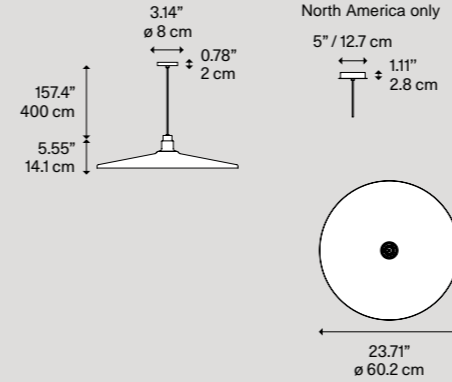

| Light source<br>Sorgente luminosa   | Structure<br>Montatura | Diffuser<br>Diffusore | Code<br>Codice | N. America<br>Code |
|-------------------------------------|------------------------|-----------------------|----------------|--------------------|
| LED E27 G95<br>1 max 25W            | Black                  | Silver                | 508007         | —                  |
|                                     |                        | Deep black            | 508008         | —                  |
| LED G30<br>Medium Base<br>1 max 25W | Black                  | Silver                | —              | 508307             |
|                                     |                        | Deep black            | —              | 508308             |

BULBS not included  
LAMPADINE non include

Net Weight/ Peso Netto: 2 kg

Pack/ Colli: 2



Vinyl Large, Deep black  
Vinyl Small, Silver

# Vinyl

Wall/ Ceiling

## Vinyl Large

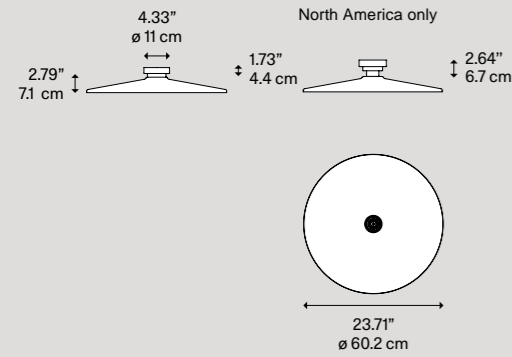

| Light source<br>Sorgente luminosa   | Structure<br>Montatura | Diffuser<br>Diffusore | Code<br>Codice | N. America<br>Code |
|-------------------------------------|------------------------|-----------------------|----------------|--------------------|
| LED E27 G95<br>1 max 25W            | Black                  | Silver                | 508003         | —                  |
|                                     |                        | Deep black            | 508004         | —                  |
| LED G30<br>Medium Base<br>1 max 25W | Black                  | Silver                | —              | 508303             |
|                                     |                        | Deep black            | —              | 508304             |

BULBS not included  
LAMPADINE non incluse

Net Weight/ Peso Netto: 1.8 kg

Pack/ Colli: 2

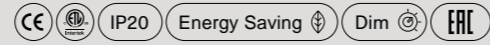

Wall/ Ceiling

## Vinyl Small

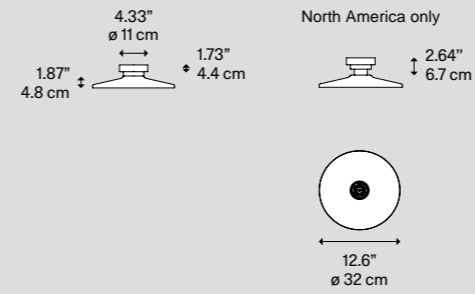

| Light source<br>Sorgente luminosa | Structure<br>Montatura | Diffuser<br>Diffusore | Code<br>Codice | N. America<br>Code |
|-----------------------------------|------------------------|-----------------------|----------------|--------------------|
| LED E27<br>1 max 25W              | Black                  | Silver                | 508001         | —                  |
|                                   |                        | Deep black            | 508002         | —                  |
| LED<br>Medium Base<br>1 max 25W   | Black                  | Silver                | —              | 508301             |
|                                   |                        | Deep black            | —              | 508302             |

BULBS not included  
LAMPADINE non incluse

Net Weight/ Peso Netto: 0.83 kg

Pack/ Colli: 2



**Materials** Metal diffuser  
Diffusore in metallo

**Colors** Silver  
Deep black

**Light** Lamp providing shielded / indirect / direct light according to the light bulb  
commercial light bulb socket  
Lampada a luce schermata / indiretta / diretta a seconda della lampadina  
Predisposizione lampadine commerciali

Vinyl Large, Deep black  
Vinyl Small, Silver





Design solutions: the versatility of Lodes canopies lends a further opportunity to personalise living spaces, whether domestic or public.

Soluzioni di design: la versatilità dei rosoni Lodes aggiunge un'ulteriore opportunità di personalizzazione degli spazi abitativi, domestici e pubblici.

### Cluster Suspension lamps



Cage Small  
A, B, C, D

Flask A,B,C  
A, B, C, D

Fork Small  
A, B, C, D

Gask  
A, B, C, D

Glass Drop  
A, B, C, D

Urban Concrete 25  
A, B, C, D

### Cluster Systems

| Canopies<br>Rosoni | Typology<br>Tipologia       | Variants<br>Varianti  | Pag.   |
|--------------------|-----------------------------|---|--|
|                    | <b>A</b><br>Single Canopy   | A.1 Single Mini<br>A.2 Recessed Micro<br>A.3 Wall Standard<br>A.4 Single Standard   | 80<br>80<br>80<br>80                               |
|                    | <b>B</b><br>Track Systems   | B.1 Short<br>B.2 Long   | 81<br>82   |
|                    | <b>C</b><br>Cluster Systems | C.1 3 Lights Round<br>C.2 5 Lights Round<br>C.3 7 Lights Round<br>C.4 14 Lights Round<br>C.5 24 Lights Round<br>C.6 36 Lights Round<br>C.7 7 Lights Rectangular<br>C.8 14 Lights Rectangular<br>C.9 28 Lights Rectangular | 83<br>83<br>83<br>83<br>84<br>84<br>85<br>85<br>85 |
|                    | <b>D</b><br>Radial Systems  | D.1 Single or Double Radial Canopy<br>D.2 4 Lights Radial<br>D.3 12 Lights Radial<br>D.4 28 Lights Radial   | 86<br>87<br>87<br>87                               |

Single Canopy

### Single Mini

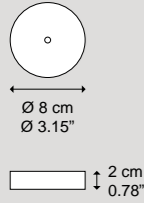

| Description<br>Descrizione               | Metal structure<br>Struttura in metallo     | Code<br>Codice | Code<br>Codice | N. America<br>Code |
|--|---|----------------|----------------|--------------------|
| Single ceiling bracket small size        | ● Matte White – 9010<br>Bianco Opaco – 9010 | Single system  | 500033         | —                  |
| Rosone per lampada singola versione mini | ● Matte Black – 9005<br>Nero Opaco – 9005   |                | 500034         | —                  |
|  | ◐ Chrome<br>Cromo                           |                | 500036         | —                  |

Net weight/ Peso netto: 0.13 kg Pack/ Colli: 1



Recessed Canopy

### Recessed Micro

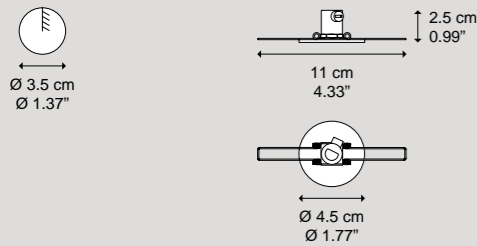

| Description<br>Descrizione                               | Metal structure<br>Struttura in metallo     | Code<br>Codice  | Code<br>Codice | N. America<br>Code |
|--|---|-----------------|----------------|--------------------|
| Recessed bracket for single lamp max capacity 3.5 kg     | ● Matte White – 9010<br>Bianco Opaco – 9010 | Recessed system | 500037         | —                  |
| Rosone da incasso per lampada singola portata max 3.5 kg | ◐ Chrome<br>Cromo                           |                 | 500040         | —                  |
|  | ● Matte Black – 9005<br>Nero Opaco – 9005   |                 | 500065         | —                  |

Net weight/ Peso netto: 0.032 kg Pack/ Colli: 1



Wall Bracket

### Wall Standard

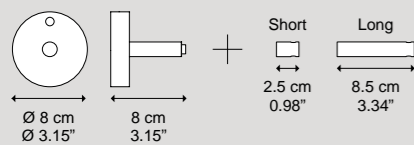

| Description<br>Descrizione                           | Metal structure<br>Struttura in metallo | Code<br>Codice  | Code<br>Codice | N. America<br>Code |
|--|---|-----------------|----------------|--------------------|
| Wall bracket for suspension modular system           | ◐ Chrome<br>Cromo                       | Recessed system | 500038         | 500338             |
| Supporto a parete per sistema modulare a sospensione |   |                 |                |                    |

Net weight/ Peso netto: 0.8 kg Pack/ Colli: 1



Single Canopy

### Single Standard

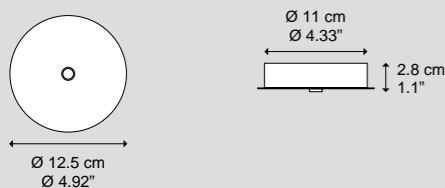

| Description<br>Descrizione                   | Metal structure<br>Struttura in metallo     | Code<br>Codice | Code<br>Codice | N. America<br>Code |
|--|---|----------------|----------------|--------------------|
| Single ceiling bracket standard size         | ● Matte White – 9010<br>Bianco Opaco – 9010 | Single system  | 500013         | 500513             |
| Rosone per lampada singola versione standard | ◐ Chrome<br>Cromo                           |                | —              | 500506             |
|  | ● Matte Black – 9005<br>Nero Opaco – 9005   |                | —              | 500511             |

Net weight/ Peso netto: 0.4 kg Pack/ Colli: 1



RECESSED MICRO ► Suitable for ceilings up to 2.4 cm thickness. WALL STANDARD ► Both accessories in the two available lengths are supplied in the box with the wall bracket.

RECESSED MICRO ► Adatta per soffitti fino a 2.4 cm di spessore. WALL STANDARD ► Entrambi gli accessori nelle due diverse lunghezze sono inclusi nella confezione con il supporto a parete.

Track System

### Short Lights Track

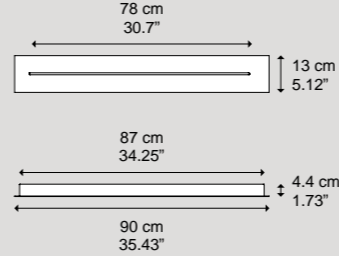

Net weight/ Peso netto: 5.5 kg Pack/ Colli: 1

| Description<br>Descrizione                                   | Structure finish<br>Finitura struttura                   | System<br>Sistema | Code<br>Codice | N. America<br>Code |
|--|--|-------------------|----------------|--------------------|
| Multiple linear track standard version max 7 suspensions     | ● Matte White – 9010<br>Bianco Opaco – 9010              | Track system      | 500029         | 500329             |
|  | ● Matte Black – 9005 <sup>NEW</sup><br>Nero Opaco – 9005 |                   | 500066         | 500366             |
| Binario lineare multiplo versione standard max 7 sospensioni |  |                   |                |                    |



### Short Track System

| Maximum quantity<br>Quantità massima        |                        | Maximum quantity<br>Quantità massima         |                        |
|---|------------------------|--|------------------------|
| Suspension aligned<br>Sospensione allineata |                        | Staggered suspension<br>Sospensione sfalsata |                        |
| Max 3                                       | mod. Cage Small        | Max 5  | mod. Cage Small        |
| Max 3                                       | mod. Urban Concrete 25 | Max 6  | mod. Urban Concrete 25 |
| Max 3                                       | mod. Fork Small        | Max 6  | mod. Fork Small        |
| Max 4                                       | mod. Gask              | Max 7  | mod. Gask              |
| Max 6                                       | mod. Glass Drop        | Max 7  | mod. Glass Drop        |
| Max 5                                       | mod. Flask A           | Max 7  | mod. Flask A           |
| Max 3                                       | mod. Flask B           | Max 5  | mod. Flask B           |
| Max 3                                       | mod. Flask C           | Max 6  | mod. Flask C           |

Track System

## Long Lights Track



Net weight/ Peso netto: 8.8 kg Pack/ Colli: 1

| Description<br>Descrizione   | Structure finish<br>Finitura struttura                       | System<br>Sistema | Code<br>Codice | N. America<br>Code |
|--|--|-------------------|----------------|--------------------|
| Multiple linear track<br>standard version<br>max 11 suspensions        | ● Matte White – 9010<br>Bianco Opaco – 9010                  | Track system      | 500030         | 500330             |
|  | ● Matte Black – 9005 <small>NEW</small><br>Nero Opaco – 9005 |                   | 500067         | 500367             |
| Binario lineare<br>multiplo versione<br>standard<br>max 11 sospensioni |  |                   |                |                    |



## Long Track System

| Maximum quantity<br>Quantità massima        |                        | Maximum quantity<br>Quantità massima         |                        |
|---|------------------------|--|------------------------|
| Suspension aligned<br>Sospensione allineata |                        | Staggered suspension<br>Sospensione sfalsata |                        |
| Max 5                                       | mod. Cage Small        | Max 9  | mod. Cage Small        |
| Max 6                                       | mod. Urban Concrete 25 | Max 10                                       | mod. Urban Concrete 25 |
| Max 6                                       | mod. Fork Small        | Max 10                                       | mod. Fork Small        |
| Max 8                                       | mod. Gask              | Max 11                                       | mod. Gask              |
| Max 10                                      | mod. Glass Drop        | Max 11                                       | mod. Glass Drop        |
| Max 9                                       | mod. Flask A           | Max 11                                       | mod. Flask A           |
| Max 5                                       | mod. Flask B           | Max 9  | mod. Flask B           |
| Max 6                                       | mod. Flask C           | Max 10                                       | mod. Flask C           |

Cluster System

## 3 Lights Round Cluster



Net weight/ Peso netto: 3.55 kg Pack/ Colli: 1

| Description<br>Descrizione            | Structure finish<br>Finitura struttura                       | System<br>Sistema | Code<br>Codice | N. America<br>Code |
|---------------------------------------|--|-------------------|----------------|--------------------|
| Round canopy<br>for 3 suspensions     | ● Matte White – 9010<br>Bianco Opaco – 9010                  | Cluster system    | 500014         | 500514             |
| Rosone circolare<br>per 3 sospensioni | ● Matte Black – 9005 <small>NEW</small><br>Nero Opaco – 9005 |                   | 500058         | 500558             |



## 5 Lights Round Cluster



Net weight/ Peso netto: 3.55 kg Pack/ Colli: 1

| Description<br>Descrizione            | Structure finish<br>Finitura struttura                       | System<br>Sistema | Code<br>Codice | N. America<br>Code |
|---------------------------------------|--|-------------------|----------------|--------------------|
| Round canopy<br>for 5 suspensions     | ● Matte White – 9010<br>Bianco Opaco – 9010                  | Cluster system    | 500015         | 500515             |
| Rosone circolare<br>per 5 sospensioni | ● Matte Black – 9005 <small>NEW</small><br>Nero Opaco – 9005 |                   | 500059         | 500559             |



## 7 Lights Round Cluster

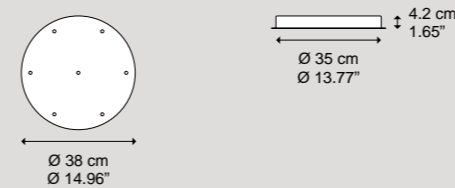

Net weight/ Peso netto: 3.55 kg Pack/ Colli: 1

| Description<br>Descrizione            | Structure finish<br>Finitura struttura                       | System<br>Sistema | Code<br>Codice | N. America<br>Code |
|---------------------------------------|--|-------------------|----------------|--------------------|
| Round canopy<br>for 7 suspensions     | ● Matte White – 9010<br>Bianco Opaco – 9010                  | Cluster system    | 500016         | 500516             |
| Rosone circolare<br>per 7 sospensioni | ● Matte Black – 9005 <small>NEW</small><br>Nero Opaco – 9005 |                   | 500060         | 500560             |



## 14 Lights Round Cluster

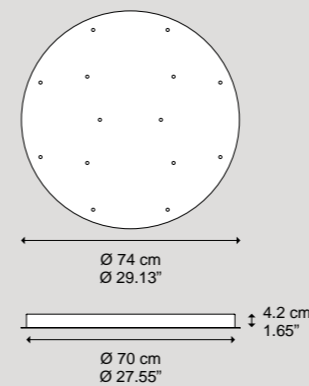

Net weight/ Peso netto: 14.14 kg Pack/ Colli: 1

| Description<br>Descrizione             | Structure finish<br>Finitura struttura                       | System<br>Sistema | Code<br>Codice | N. America<br>Code |
|--|--|-------------------|----------------|--------------------|
| Round canopy<br>for 14 suspensions     | ● Matte White – 9010<br>Bianco Opaco – 9010                  | Cluster system    | 500017         | 500517             |
| Rosone circolare<br>per 14 sospensioni | ● Matte Black – 9005 <small>NEW</small><br>Nero Opaco – 9005 |                   | 500057         | 500557             |



Cluster System

## 24 Lights Round Cluster

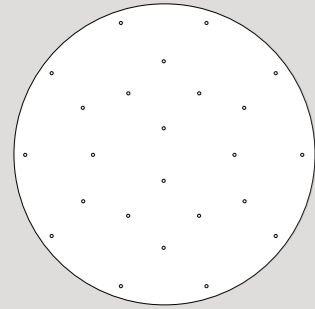

Ø 100 cm  
Ø 39.37"

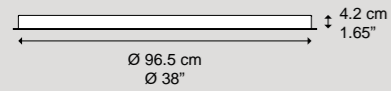

Ø 96.5 cm  
Ø 38"

Net weight/ Peso netto: 23.5 kg Pack/ Colli: 1

| Description<br>Descrizione             | Structure finish<br>Finitura struttura                   | System<br>Sistema | Code<br>Codice | N. America<br>Code |
|--|--|-------------------|----------------|--------------------|
| Ceiling bracket<br>for 24 suspensions  | ● Matte White – 9010<br>Bianco Opaco – 9010              | Cluster system    | 500025         | 500525             |
| Rosone circolare<br>per 24 sospensioni | ● Matte Black – 9005 <sup>NEW</sup><br>Nero Opaco – 9005 |                   | 500056         | 500556             |



## 36 Lights Round Cluster

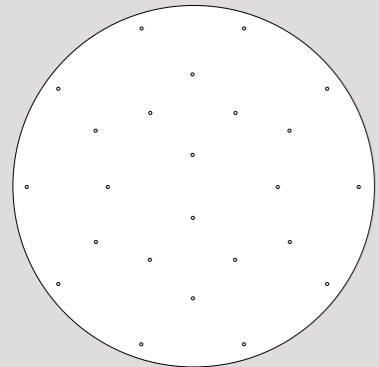

Ø 120 cm  
Ø 47.24"

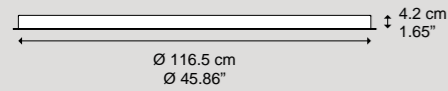

Ø 116.5 cm  
Ø 45.86"

Net weight/ Peso netto: 32.7 kg Pack/ Colli: 1

|  |  |                |        |        |
|--|--|----------------|--------|--------|
| Ceiling bracket<br>for 36 suspensions  | ● Matte White – 9010<br>Bianco Opaco – 9010              | Cluster system | 500018 | 500518 |
| Rosone circolare<br>per 36 sospensioni | ● Matte Black – 9005 <sup>NEW</sup><br>Nero Opaco – 9005 |                | 500061 | 500561 |



Cluster System

## 7 Lights Rectangular Cluster

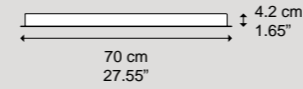
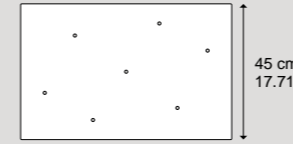

Net weight/ Peso netto: 9.89 kg Pack/ Colli: 1

| Description<br>Descrizione               | Structure finish<br>Finitura struttura                   | System<br>Sistema | Code<br>Codice | N. America<br>Code |
|--|--|-------------------|----------------|--------------------|
| Rectangular canopy<br>for 7 suspensions  | ● Matte White – 9010<br>Bianco Opaco – 9010              | Cluster system    | 500019         | 500519             |
| Rosone rettangolare<br>per 7 sospensioni | ● Matte Black – 9005 <sup>NEW</sup><br>Nero Opaco – 9005 |                   | 500062         | 500562             |



## 14 Lights Rectangular Cluster

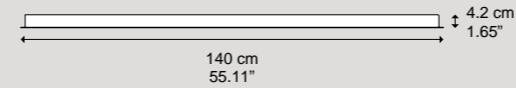
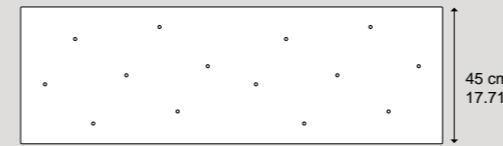

Net weight/ Peso netto: 17.1 kg Pack/ Colli: 1

|   |  |                |        |        |
|---|--|----------------|--------|--------|
| Rectangular canopy<br>for 14 suspensions  | ● Matte White – 9010<br>Bianco Opaco – 9010              | Cluster system | 500020 | 500520 |
| Rosone rettangolare<br>per 14 sospensioni | ● Matte Black – 9005 <sup>NEW</sup><br>Nero Opaco – 9005 |                | 500063 | 500563 |



## 28 Lights Rectangular Cluster

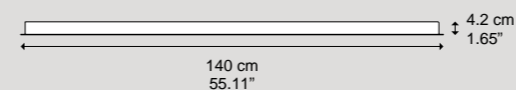
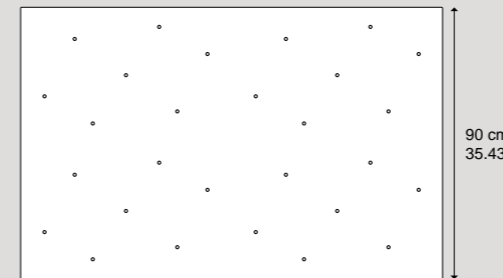

Net weight/ Peso netto: 31.1 kg Pack/ Colli: 1

|   |  |                |        |        |
|---|--|----------------|--------|--------|
| Rectangular canopy<br>for 28 suspensions  | ● Matte White – 9010<br>Bianco Opaco – 9010              | Cluster system | 500021 | 500521 |
| Rosone rettangolare<br>per 28 sospensioni | ● Matte Black – 9005 <sup>NEW</sup><br>Nero Opaco – 9005 |                | 500064 | 500564 |



## Radial System

## Swag Kit for Radial Canopy

| Description<br>Descrizione  | Polycarbonate structure<br>Struttura in policarbonato | System<br>Sistema | Code<br>Codice | N. America<br>Code |
|---|---|-------------------|----------------|--------------------|
| <p>Wall and ceiling anchor for Radial System power cable<br/>max Ø 7 mm<br/>max capacity 5 kg</p> <p>Cilindro di decentramento per Sistema Radiale cavo elettrico<br/>max Ø 7 mm<br/>Portata max 5 kg</p> | <p>Clear<br/>Trasparente</p>                          | Radial system     | 500109         | 500109             |
| <p>Net weight/ Peso netto: 0.02 kg    Pack/ Colli: 1</p>  |   |                   |                |                    |



## Single or Double Radial Canopy

| Description<br>Descrizione   | Structure finish<br>Finitura struttura   | System<br>Sistema | Code<br>Codice | N. America<br>Code |
|--|--|-------------------|----------------|--------------------|
| <p>Ceiling bracket for single decentralized suspension or double opposed</p> <p>Rosone circolare per sospensione singola decentrata o doppia contrapposta</p> <p>Radial Swag Kit not included</p> <p>Radial Swag Kit non incluso</p> | <p>Matte White – 9010<br/>Bianco Opaco – 9010</p> <p>Matte Black – 9005 <sup>NEW</sup><br/>Nero Opaco – 9005</p> | Radial system     | 500026         | 500326             |
| <p>Net weight/ Peso netto: 0.35 kg    Pack/ Colli: 1</p>   |  |                   |                |                    |

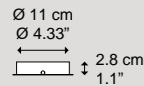

## Radial System

## 4 Lights Radial Cluster

| Description<br>Descrizione  | Structure finish<br>Finitura struttura   | System<br>Sistema | Code<br>Codice | N. America<br>Code |
|---|--|-------------------|----------------|--------------------|
| <p>Radial canopy max 4 suspensions</p> <p>Rosone radiale max 4 sospensioni</p> <p>Radial Swag Kit not included</p> <p>Radial Swag Kit non incluso</p> | <p>Matte White – 9010<br/>Bianco Opaco – 9010</p> <p>Matte Black – 9005 <sup>NEW</sup><br/>Nero Opaco – 9005</p> | Radial system     | 500041         | 500341             |
| <p>Net weight/ Peso netto: 0.35 kg    Pack/ Colli: 1</p>  |  |                   |                |                    |

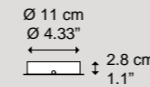

## 12 Lights Radial Cluster

| Description<br>Descrizione   | Structure finish<br>Finitura struttura   | System<br>Sistema | Code<br>Codice | N. America<br>Code |
|--|--|-------------------|----------------|--------------------|
| <p>Radial canopy max 12 suspension</p> <p>Rosone radiale max 12 sospensioni</p> <p>Radial Swag Kit not included</p> <p>Radial Swag Kit non incluso</p> | <p>Matte White – 9010<br/>Bianco Opaco – 9010</p> <p>Matte Black – 9005 <sup>NEW</sup><br/>Nero Opaco – 9005</p> | Radial system     | 500027         | 500327             |
| <p>Net weight/ Peso netto: 1.05 kg    Pack/ Colli: 1</p>   |  |                   |                |                    |

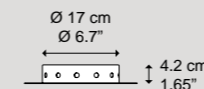
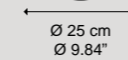
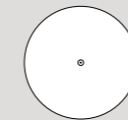

## 28 Lights Radial Cluster

| Description<br>Descrizione   | Structure finish<br>Finitura struttura   | System<br>Sistema | Code<br>Codice | N. America<br>Code |
|--|--|-------------------|----------------|--------------------|
| <p>Radial canopy max 28 suspension</p> <p>Rosone radiale max 28 sospensioni</p> <p>Radial Swag Kit not included</p> <p>Radial Swag Kit non incluso</p> | <p>Matte White – 9010<br/>Bianco Opaco – 9010</p> <p>Matte Black – 9005 <sup>NEW</sup><br/>Nero Opaco – 9005</p> | Radial system     | 500028         | 500328             |
| <p>Net weight/ Peso netto: 3.35 kg    Pack/ Colli: 1</p>   |  |                   |                |                    |

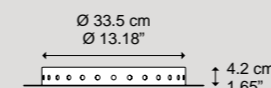
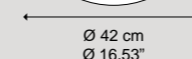
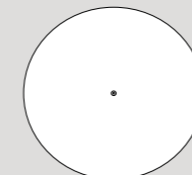

## DEU

Eine vielseitige Kollektion von Design-Leuchten für Wohnungen und öffentliche Räume feiert die Partnerschaft zwischen Diesel Living und Lodes. Der unverkennbare Stil von Diesel nimmt nun eine neue dynamische und zeitgenössische Form an, um neuartige Lichtgeschichten zu erzählen. Rock und Pop, spielerisch und funktional, lässig und industriell – Diesels kreatives Gespür verleiht der Leuchtenkollektion ihren freigeistigen Lifestyle-Touch.

## ESP

Una versátil colección de lámparas para espacios públicos y privados celebra la colaboración entre Diesel Living y Lodes. El inconfundible estilo de Diesel adopta nuevas formas dinámicas y contemporáneas para contar novedosas historias de luz. Rock y pop, lúdica y funcional, casual e industrial, la intuición creativa de Diesel otorga su irreverente toque lifestyle a una brillante gama de lámparas.

## FRA

Une collection polyvalente de lampes de décoration pour intérieurs privés et publics célèbre le partenariat entre Diesel Living et Lodes. Le style distinctif de Diesel prend désormais de nouvelles formes dynamiques et contemporaines pour raconter des histoires de lumière inédites. Rock et pop, ludique et fonctionnelle, décontractée et industrielle, l'intuition créative de Diesel apporte sa touche lifestyle irrévérencieuse à une étincelante gamme de lampes.

## RUS

Универсальная коллекция светильников для частных и общественных интерьеров отметила партнерство между Diesel Living и Lodes. Характерный стиль Diesel принимает новые динамичные и современные формы, рассказывая новые истории при помощи света. Рок и поп, игривая и функциональная, повседневная и индустриальная творческая интуиция Diesel привносит своеобразие своего смелого жизненного стиля в яркую и живую гамму светильников.

## CHI

系列广泛的居家和公共室内装饰灯件提升着Diesel Living和Lodes的合作伙伴关系。今天，Diesel 独特的设计语言采用了新的当代和动态形式动感十足且具有当代风格的全新形式，并通过光线讲述新鲜的故事以讲述关于光线的新鲜轶事。摇滚与流行、娱乐性与功能性、休闲性与工业性，Diesel的创意直觉为活力四射的照明系列赋予顽强不羁的生活方式。

## DEU

Die neue Diesel Living with Lodes-Kollektion besteht aus drei exklusiven Ergänzungen (Flask, Vinyl und Urban Concrete) sowie fünf modernisierten Bestsellern (Cage, Fork, Gask, Glass Drop und Pipe) und bietet eine vielseitige Auswahl an Beleuchtungselementen für Wohnräume und öffentliche Innenräume.

Die Kollektion ist inspiriert von kontrastierenden Gegensätzen, wie Realität und Wahrnehmung, und gleichzeitig durchdrungen von DIESELs richtungsweisender Designsprache und den unverwechselbaren Markengrundsätzen von Lodes. Alle Lampen sind für die Verwendung von handelsüblichen Leuchtmitteln ausgelegt, so dass die Wahl der Lichtart völlig frei bleibt. Wir bieten die Emotion, ihr wählt die Lichtquelle!

## ESP

Formada por tres novedades exclusivas (Flask, Vinyl y Urban Concrete) y cinco superventas renovados (Cage, Fork, Gask, Glass Drop y Pipe), la nueva colección Diesel Living with Lodes presenta una selección versátil de artículos para la iluminación de espacios residenciales e interiores públicos.

La colección se inspira en contrastes antitéticos, como la realidad y la percepción, y está impregnada del lenguaje formal irreverente y direccional de DIESEL combinado con los principios distintivos de la marca Lodes.

Todas las lámparas pueden utilizar bombillas comerciales para permitir una libertad total de elección del tipo de luz. ¡Nosotros ofrecemos la emoción, vosotros elegís la fuente de luz!

## FRA

Composée de trois ajouts exclusifs (Flask, Vinyl et Urban Concrete) et de cinq best-sellers réactualisés (Cage, Fork, Gask, Glass Drop et Pipe), la nouvelle collection Diesel Living with Lodes propose une sélection polyvalente d'éléments d'éclairage pour les espaces résidentiels et les intérieurs publics.

La collection s'inspire des oppositions dans les contrastes, telles que la réalité et la perception, tout en étant imprégnée du langage de conception directionnel irrévérencieux de DIESEL et des principes distinctifs de la marque Lodes.

Toutes les lampes sont prédisposées pour l'utilisation d'ampoules commerciales afin de laisser la plus grande liberté de choix sur le type de lumière. Nous sommes là pour vous offrir des émotions, à vous de choisir la source lumineuse!

## RUS

### 2021 АССОРТИМЕНТ СВЕТИЛЬНИКОВ

Новая коллекция Diesel Living with Lodes, состоящая из трех эксклюзивных новых моделей (Flask, Vinyl и Urban Concrete), а также пяти обновленных бестселлеров (Cage, Fork, Gask, Glass Drop и Pipe), предлагает покупателям универсальный выбор светильников, предназначенных для жилых и общественных помещений.

Коллекция вдохновляется контрастами и противоположностями, соединяя в себе реальность и восприятие, она впитала в себя дерзкий стиль DIESEL и отличительные характеристики бренда Lodes.

Все светильники могут использоваться с обычными имеющимися в продаже лампочками, оставляя полную свободу выбора типа освещения. Мы дарим эмоции, вы выбираете источник света!

## CHI

## 2021 照明品类

涵盖三款独家新品 (Flask, Vinyl和Urban Concrete)以及五款翻新畅销品 (Cage, Fork, Gask, Glass Drop 和 Pipe), 全新 Diesel Living with Lodes 系列为家居空间与公共室内环境奉送选择多样的照明件。

该系列的灵感来自诸如现实与感知等相反的对立面,同时融入了DIESEL顽强的定向设计语言和Lodes独特的品牌宗旨。

所有灯件均设有商用灯泡的预留接口,可使您完全自由地选择光线类型。我们奉送情感,你们选择光源!

## DEU

Ihr Ursprung befindet sich "unter Tage": Cage ist inspiriert von den Lampen der Bergleute und Arbeiter, geschützt durch einen Metallkäfig, der hier zum dekorativen Element wird und der Leuchte ihren Namen verleiht.

Der Kontrast zwischen der Zartheit des mundgeblasenen Glases, des eleganten glänzenden Diffusors und der Härte des Stahls des äußeren Käfigs mit seiner unregelmäßigen Struktur, macht Cage unverwechselbar und verleiht ihr einen eleganten Vintage-Touch.

Der Diffusor ist in zwei Farben erhältlich, white und bronze, die beliebig mit dem Metallkäfig in white oder black Ausführung kombiniert werden können. In der Version Bronze verfügt die Lichtquelle über einen doppelten Kern: im ausgeschalteten Zustand reflektiert die glänzende Glasoberfläche die Geometrie des Käfigs, im eingeschalteten Zustand verschwindet die Reflexion und die Farbe des Glases verströmt ein wärmeres Licht.

Cage Large, mit einem Durchmesser von 46 cm, ist eine Hängeleuchte von großer Wirkung. Die Version Small, mit ihren 27,5 cm Durchmesser, eignet sich für zahlreiche Kompositionen mit metropolitanem Charakter.

## ESP

Su origen es "underground": Cage se inspira en las lámparas de los mineros y los obreros, protegidas por una jaula metálica, que en este caso se convierte en un elemento decorativo y le da el nombre a la lámpara.

El contraste entre la delicadeza del vidrio soplado del elegante difusor brillante y la dureza del acero de la jaula externa de estructura irregular hace que Cage sea inconfundible y le da un toque elegantemente vintage.

El difusor está disponible en dos colores, white (blanco) y bronze (bronce), que pueden combinarse como se prefiera con la jaula metálica en los acabados white (blanco) o black (negro). En la versión bronze le regala a la fuente de luz dos aspectos distintos: cuando está apagada la superficie brillante del vidrio refleja las geometrías de la jaula y cuando está encendida el reflejo desaparece y el color del vidrio es más cálido.

Cage Large, con un diámetro de 46 cm, es una lámpara colgante con un gran efecto. La versión Small, con 27,5 cm de diámetro, se presta a múltiples composiciones de estilo metropolitano.

## FRA

Son origine est « underground » : Cage s'inspire des lampes des mineurs et des ouvriers, protégées par une petite cage en métal qui devient ici un élément de décoration et donne son nom à la lampe.

Le contraste entre la délicatesse du verre soufflé de l'élégant diffuseur brillant et la dureté de l'acier de la cage à structure irrégulière rend Cage unique et lui octroie une touche élégamment vintage.

Le diffuseur est disponible en deux couleurs, white et bronze, à combiner au choix avec la cage en métal dans les finitions white ou black. Dans la version bronze, la source lumineuse lui octroie un double caractère : éteinte, la surface brillante du verre reflète les géométries de la cage, éclairée, le reflet disparaît et la couleur du verre devient plus chaude.

Cage Large, avec son diamètre de 46 cm, est une lampe à suspension de grand effet. La version Small, avec ses 27,5 cm de diamètre, est idéale pour des compositions multiples au style métropolitain.



## RUS

Происхождение этой модели спрятано “под землей”: Sage был спроектирован под влиянием формы шахтерских фонарей, защищенных металлической клеткой, которая превращается в декоративный элемент и дает лампе ее название.

Контраст между хрупкостью выдувного стекла элегантно полированного диффузора и твердостью стали наружной клетки с неравномерной структурой делает Sage неповторимым элементом, характеризующимся элегантно винтажным видом.

Диффузор выпускается в двух вариантах цвета: white и bronze; они могут сочетаться по желанию с металлической клеткой с отделкой white или black. В бронзовом варианте источник света создает двойной эффект: при выключенной лампе блестящая поверхность стекла отражает геометрию клетки, при включении отражение исчезает, а цвет стекла становится теплее.

Sage Large, диаметром 46 см - это подвесная лампа, производящая огромный эффект. Версия Small, диаметром 27,5 см, подходит для создания множественных композиций в урбанистическом стиле.

## CHI

这款灯件的起源在“地下”: Cage的灵感源自矿工和工人用的探照灯,它受护于一只金属笼,这只笼子继而成为此处的装饰性元素以及这款灯件的命名要素。

闪亮灯罩所用的吹制玻璃之优雅,与结构不甚规则的外笼钢体之硬度形成对比,造就了Cage的独具一格,并为其赋予一丝典雅的复古气息。

灯罩提供两种颜色, white(白色) 和bronze(青铜色),可按喜好与white(白色)或black(黑色)饰面的金属笼相搭配。青铜色版本中,光源为其赋予双重灵魂:关灯时,玻璃的光亮表面会反射出笼子的几何形状,亮灯时,反射会消失且玻璃色彩也会愈发变暖。

Cage Large, 直径46 厘米,是一款效果极佳的悬吊灯。Small版本,以其27,5厘米的直径,可形成具有都市风情的多样组合。

## DEU

Inspiriert von den einzigartigen Formen von Glasflaschen, die in wissenschaftlichen Labors verwendet werden, weist Flask eine metallische Oberfläche auf, die durch die Beleuchtung den Glascharakter offenbart.

Die Form erinnert an ein Objekt mit industriellem Flair, bei dem der visuelle Kontrast zwischen der Leichtigkeit des mundgeblasenen Glases und der Solidität der metallischen Oberfläche koexistieren. Das Objekt wird durch den Kontrast zwischen der matten metallischen Außenfläche und der glänzenden Innerseite, die mit dem Licht leuchtet und tänzerisch mit ihm zusammen spielt, noch verstärkt.

Wenn die Lampe leuchtet, enthüllt das Design von Flask eine im Glaskörper schwebende Lichtquelle, mit einer inneren glänzenden leuchtenden Oberfläche, die mit den Reflexen der anderen in der Nähe platzierten Lampen einen gewagten visuellen Effekt erzeugt. Der Lampenhals wurde so gestaltet, dass er bei eingeschaltetem Licht dunkel bleibt, wodurch die Silhouette des Objekts und seine industrielle Oberfläche hervorgehoben werden.

Am oberen Ende versiegelt eine schwarze Silikonkappe mit DIESEL-Logo die Lampe und verleiht ihr einen extrem industriellen Touch.

Mit drei verfügbaren Formen und zwei Ausführungen, die an industrielle Welten erinnern: metallic black und mineral sand, kann Flask auch in Clustern platziert werden. Flask ein dekoratives Objekt, das sich auch für Cluster-Kompositionen eignet, um lebendige Lichtinstallationen mit einem äußerst zeitgenössischen Effekt zu schaffen.



## ESP

Inspirada en las formas únicas de las botellas de vidrio utilizadas en los laboratorios científicos, Flask se caracteriza por una superficie metálica que revela su auténtica naturaleza de vidrio cuando está encendida.

Su forma simula un objeto caracterizado por una textura industrial en el que conviven el contraste visualmente llamativo entre la ligereza del vidrio soplado y la solidez del acabado metálico. La lámpara se ve realizada por el contraste entre la superficie exterior metálica mate y el interior brillante que, cuando está encendida, se ilumina con una inesperada danza de luz.

Cuando está encendida la lámpara de suspensión Flask revela una fuente de luz flotante en el cuerpo de vidrio, ilumina la superficie interior reluciente para crear un efecto visual atrevido. Por otro lado, el cuello de la lámpara se ha diseñado para que siga siendo oscuro realzando así la silueta de la pieza y su superficie industrial. En el extremo superior un tapón de silicona negra con el logotipo DIESEL cierra la lámpara y le da un toque sumamente industrial.

Con tres formas disponibles y dos acabados que evocan ambientes industriales - metallic black (negro metalizado) y mineral sand (arena mineral)- Flask es una pieza decorativa que también se presta a composiciones en serie para crear vibrantes instalaciones de luz con un efecto sumamente actual.

## FRA

S’inspirant des formes uniques des flacons en verre utilisés dans les laboratoires scientifiques, Flask présente une surface métallique qui révèle sa nature en verre lorsqu’il est allumé.

Sa forme rappelle un objet à texture industrielle dont le fort contraste visuel entre la légèreté du verre soufflé et la matéricité de la finition métallique cohabitent. La lampe est encore davantage mise en valeur par le contraste entre la surface extérieure métallisée mate et l’intérieur brillant qui s’illumine dans une danse spontanée de lumière.



Éclairée, la suspension Flask révèle une source lumineuse qui fluctue dans le corps de verre, illumine la surface interne brillante et crée un effet visuel audacieux. Le col de la lampe a été conçu pour rester sombre, mettant ainsi en valeur la forme de la pièce et sa surface au style industriel. À l'extrémité supérieure, un bouchon en silicone noir affichant le logo DIESEL scelle la lampe et lui octroie un look fortement industriel. Avec trois formes disponibles et deux finitions évoquant des mondes industriels - metallic black et mineral sand - Flask est une pièce décorative qui se prête également à des compositions sur cluster pour créer des installations vibrantes de lumière à l'effet extrêmement contemporain.

---

**RUS**

Вдохновленная уникальной формой стеклянных флаконов, используемых в научных лабораториях, Flask имеет металлическую поверхность, которая при освещении раскрывает ее стеклянную природу. Форма светильника напоминает промышленный предмет, с выраженным зрительным контрастом между легкостью дутого стекла и материальностью металлической отделки. Красота светильника дополнительно подчеркивается контрастом между матовой металлической наружной стороной и глянцевой внутренней поверхностью, играющей световыми бликами, когда светильник включен. Горящий подвесной светильник Flask открывает источник света, как будто плавающий внутри стеклянного корпуса, который освещает блестящую внутреннюю поверхность и создает смелый визуальный эффект. Верхняя часть лампы была спроектирована таким образом, чтобы всегда оставаться неосвещенной, подчеркивая линии лампы и ее промышленную поверхность. Черный силиконовый колпачок с логотипом DIESEL закрывает лампу сверху и подчеркивает индустриальный стиль. Предлагаются три варианта формы и два варианта отделки: metallic black и mineral sand. Flask - это декоративный элемент, который можно помещать в кластерные композиции, чтобы создавать вибрирующие световые инсталляции, отличающиеся выраженной современностью.

---

**CHI**

受科学实验室中使用的玻璃瓶之独特形状的启发,Flask的特点在于有着一块在亮灯时便会显露其玻璃本质的金属表面。它的形状令人联想起具有工业风情的物件,吹制玻璃的亮度与金属饰面的坚固度之间形成的强烈视觉对比共存于此。哑光金属外表和光泽明朗的内壁之间的对立性进一步提升了这款灯件,点亮灯光时,会闪耀令人惊叹的光舞魅影。亮灯后, Flask 悬吊灯会显露一个仿佛漂浮在玻璃灯体中的光源,照亮其光滑的内表并营造出一种大胆醒目的视觉效果。灯件颈部被设计为亮灯时保持黑暗,从而增强着作品及其工业表面的线条感。顶端处,一只带有DIESEL 徽标的黑色硅胶帽将灯件密封,并为其赋予一丝工业感十足的情调。提供三种形状和两种呼应着工业世界的饰面 - metallic black(金属黑) 和 mineral sand(矿物砂) - Flask 是一件也可安装于组合吊上进行搭配组合的装饰性作品,从而创造富有当代感且活力四射的照明装置。

---

**DEU**

Fork ist eine "Gabel" aus Stahl, auf der ein Diffusor platziert wird, der von lässiger Mode, Campingzelten und einem informellen und entschlossenen Lebensstil inspiriert ist. Ein Konzept, das in der Tisch-, Boden- und Hängeversion immer auf dem neuesten Stand ist, für jede Umgebung und jeden Moment des täglichen Lebens. Wie beim Einschalten einer Lampe im Inneren eines Campingzeltes hebt das Licht im Inneren des Diffusors die Patchwork-Struktur hervor und verstärkt die Textur der Leinwand mit sichtbaren Nähten wie bei Jeans. Der Baumwoll-Leinen-Diffusor, erhältlich in ivory und gray, kriert einen warmen und weichen Lichteffect. Der Diffusor ist um 360° verstellbar, dank der brünierten Messingösen, die in starkem Materialkontrast zur Weichheit des Gewebes stehen, und ermöglicht es, den Lichtstrahl nach Belieben einzustellen.

**FORK STEHLEUCHTE**

Die Struktur aus Metall, die den Diffusor stützt, ist in ivory o anthracite erhältlich. Die Haltestange, die diese Leuchte immer schon charakterisierte, ist an der Base drehbar und ermöglicht es somit, den Lichtstrahl in absoluter Freiheit zu regulieren.

**FORK TISCHLEUCHTE**

Die Metallstruktur schlägt die Linien, Farben und Funktionen der Stehleuchte vor, hier jedoch in der Version Small, perfekt für jeden Raum.

**FORK HÄNGELEUCHTE**

In der Ausführung Large ist Fork eine Hängeleuchte mit Einzelaufhängung von großem Charakter, dank des schwenkbaren Diffusors, der an einem tragenden Kabel aufgehängt ist. Die Version Small entfaltet ihr Potenzial bei Kompositionen mit mehrflamigen Baldachinen, deren Diffusoren den Raum mit lebhaften Lichtspielen erforschen.

---

**ESP**

Fork es un "tenedor" de acero sobre el que se apoya un difusor inspirado en la moda casual, las tiendas de campaña y un estilo de vida informal y decidido. Un concepto siempre actual articulado en las versiones de mesa, suelo y suspensión, para cualquier ambiente y momento de la vida cotidiana.

Como cuando se enciende una lámpara dentro de una tienda de campaña, la luz del interior del difusor destaca la estructura de retales y acentúa la textura de la tela con las costuras a la vista como en los vaqueros. El difusor de algodón y lino, disponible en color ivory (marfil) y gray (gris), crea un efecto luminoso cálido y tenue. El difusor, que se puede orientar a 360° gracias a los ojales de latón de color gris bélico que crean un gran contraste matérico con la suavidad de la tela, permite orientar el haz de luz como se quiera.

**FORK SUELO**

La estructura de metal que sujeta el difusor está disponible en color ivory (marfil) o anthracite (antracita). La varilla, con la inclinación que la caracteriza desde siempre, gira sobre la base y permite compartir el haz de luz con total libertad.

**FORK MESA**

La estructura de metal reitera líneas, colores y funciones de la lámpara de suelo pero en versión Small, perfecta para cualquier espacio.



**FORK COLGANTE**

En la versión Large, Fork es una lámpara colgante individual de gran carácter gracias al difusor orientable suspendido en un cable portante. La versión Small da lo mejor de sí misma en composiciones con florón múltiple, con los difusores que exploran el espacio con alegres juegos de haces de luz.

---

**FRA**

Fork est une “fourchette” d’acier sur laquelle est posé un diffuseur s’inspirant au style casual, aux tentes de camping, à un style de vie informel et dynamique. Un concept toujours actuel décliné dans les versions de table, de sol et suspension, pour chaque milieu et moment de la vie quotidienne. Comme dans une tente, la lumière du diffuseur souligne la structure en patchwork et met en valeur la texture de la toile avec coutures visibles, comme celles des jeans. Le diffuseur en coton-lin, disponible en ivory et gray, crée un effet lumineux chaud et diffus. Orientable à 360° grâce aux œillets en laiton couleur bronze, en fort contraste matérique avec la souplesse du tissu, le diffuseur permet d’orienter le faisceau lumineux comme bon nous semble.

**FORK SOL**

La structure en métal qui soutient le diffuseur est disponible en couleur ivory ou anthracite. La tige, avec l’inclinaison qui la distingue depuis toujours, pivote sur la base et permet de partager le faisceau de lumière en toute liberté.

**FORK TABLE**

La structure en métal repropose les lignes, les couleurs et les fonctions de la lampe de sol mais en version Small, idéale pour tous les espaces.

**FORK SUSPENSION**

En version Large, Fork est une suspension unique de grand caractère grâce au diffuseur orientable suspendu à un câble portant. La version Small s’exprime au mieux dans les compositions sur patères multiples, avec les diffuseurs qui scrutent l’espace dans des jeux espiègles de faisceaux lumineux.

---

**RUS**

Fork - это стальная “вилка”, на которую помещается диффузор, созданный под вдохновением повседневного стиля, походных палаток, смелого и неформального образа жизни. Всегда актуальная концепция, выпускаемая в настольной, напольной и подвесной версиях, подходит для любых помещений и жизненных ситуаций.

Как лампа, горящая внутри походной палатки, свет внутри диффузора подчеркивает лоскутную структуру и текстуру полотна, со швами наружу, как на джинсах. Льняной-хлопчатобумажный абажур выпускается в вариантах ivory и gray, и создает теплый и рассеянный световой эффект. Светильник может ориентироваться под углом 360°, благодаря латунным шарнирам цвета бронзы, резко контрастирующими с мягкостью ткани, и позволяет по желанию направлять луч света.

**FORK НАПОЛЬНЫЙ**

Металлическая структура, поддерживающая диффузор, выпускается в двух вариантах цвета, ivory или anthracite. Стержень с характерным наклоном вращается на основании и позволяет направлять луч света по желанию.

**FORK НАСТОЛЬНЫЙ**

Металлическая конструкция версии Small воспроизводит линии, цвета и функции напольного торшера, и идеально подходит для любого помещения.

**FORK ПОДВЕСНОЙ**

Версия Large Fork - это одинарный подвесной светильник, отличающийся ориентируемым диффузором, подвешенным на несущем шнуре. Версия Small лучше всего подходит для множественных композиций на потолочном креплении, включающих в себя несколько диффузоров, создающих яркую игру световых лучей.

---

**CHI**

Fork是一款将灯罩置放在上的钢“叉”形灯件,灵感源自休闲时尚、野营帐篷以及不拘小节的生活风尚。它是一种日益趋向于台式、落地式与悬吊式版本的理念,可针对每种环境与日常时刻。就像您点亮野营帐篷中的灯件时一样,灯罩内的光线会突出其拼凑而出的结构,并通过如同牛仔裤上那样的可见针脚线来增强帆布的质感。棉麻灯罩,提供ivory (象牙色)和 gray(灰色)两种颜色,营造一种温暖饱满的光亮效果。凭借与面料的柔软性形成强烈对比的枪筒色黄铜孔眼,灯罩可360度调转,使您能够随意引调光束。

**FORK 落地灯**

举持灯罩的金属结构供有ivory (象牙色)或anthracite (无烟煤色)两种颜色。一贯以倾斜为其特征的灯架,可在底座上旋转,使您能够在绝对自由的情况下分享光束。

**FORK 台灯**

金属结构重塑其线条感,拥有与落地灯同样的颜色与功能,但版本为Small型号,可完美搭配任何空间。

**FORK 悬吊灯**

Large版本的Fork 是一款特征显著的单盏悬吊灯,这得益于悬吊在一条电源缆线上的可调转式灯罩。Small 版本经在多样底盘上组合后效果更佳,灯罩会以生动活泼的光束游戏令周围空间熠熠生辉。

## DEU

Gask ist eine kleine Hängeleuchte mit großer Präsenz. Sie erweckt den Eindruck, als käme sie aus einem Emporium der 1920er Jahre oder einem Lagerhaus für Werkzeuge, aber sie erinnert auch an die Zikkurat, die heiligen terrassenförmigen Pyramiden des alten Mesopotamiens.

Gask ist ein perfekter Mix aus Materialien, die scheinbar in einem sensorischen Kontrast stehen – Glas, Stahl, Messing –, jedoch eine perfekte Kombination bilden. Der Stahlrahmen hat eine mattschwarze, raue und materielle Oberfläche mit ausgeprägtem industriellem Flair und ist mit dem Diffusor mit freiliegenden Messingbolzen kombiniert. Der zarte Diffusor aus mundgeblasenem Glas, in den Ausführungen transparent oder army green, deklariert bewusst die Präsenz der Lichtquelle im Inneren.

Gask ist eine Leuchte, die sowohl in einflammigen als auch mehrflammigen Baldachinen einen Impakt erzeugt, der durch die Kombination der beiden unterschiedlichen Oberflächen in einem Spiel von Transparenz und Opazität, noch verstärkt wird. Mit ihrem Retro-Flair, das dem praktischen Sinn für Modernität entspricht, vereint Gask in perfekter Weise Bezugnahmen auf die Vergangenheit und den gegenwärtigen Lebensstil.



## ESP

Gask es una pequeña lámpara colgante de gran presencia. Parece que haya salido de un emporio de los años 20 o de un almacén de herramientas de trabajo, pero a la vez recuerda los zigurats, las pirámides sagradas escalonadas en terrazas de la antigua Mesopotamia.

Gask es una mezcla perfecta de materiales aparentemente en contraste sensorial – vidrio, acero y latón – que crean una mixtura ideal. El armazón de acero tiene un acabado negro mate, áspero y sólido de estilo sumamente industrial, y está unido al difusor con bulones a la vista de latón. El delicado difusor de vidrio soplado, en los acabados transparent (transparente) o army green (verde militar), declara deliberadamente la presencia de la fuente de luz en el interior.

Gask es una lámpara impactante tanto por sí sola como en composiciones múltiples en florón, incluso intercalando los dos acabados distintos en un juego de transparencias y opacidad. Con su estilo retro unido al sentido práctico de la modernidad, Gask combina perfectamente las evocaciones al pasado y el estilo de vida actual.

## FRA

Gask est une lampe à suspension de petite taille mais de grande présence. Elle semble arriver tout droit d'un magasin des années Vingt ou d'un atelier. Elle fait également penser aux ziggourats, à savoir les pyramides à terrasses de l'ancienne Mésopotamie.

Gask est un mix parfait de matériaux en contraste sensoriel apparent – verre, acier, cuivre – qui créent une union idéale. La monture en acier présente une finition noir mat, rugueuse et matérielle au style fortement industriel et s'unit au diffuseur au moyen de boulons apparents en cuivre. Le diffuseur délicat en verre soufflé, dans les finitions transparent ou army green, déclare délibérément la présence, à l'intérieur, de la source lumineuse.

Gask est une lampe impactante, tant individuellement qu'en composition multiple sur patère, qui peut aussi intercaler les deux finitions dans un jeu de transparences et d'opacité. Avec son style rétro qui s'unit au sens pratique de la modernité, Gask conjugue parfaitement les références du passé et le style de vie contemporain.

## RUS

Gask - это маленький подвесной светильник, производящий большой эффект. Кажется, что он взят из универсального магазина 20-х годов или со склада рабочих инструментов, он также напоминает зиккураты, священные террасные пирамиды древней Месопотамии.

Gask представляет собой идеальное сочетание материалов, обладающих выраженным сенсорным контрастом - стекла, стали, латуни - которые создают идеальную композицию. Стальная рама имеет матовую черную отделку, шершавую и материальную, с выраженным индустриальным стилем, и соединена с диффузором с помощью латунных болтов, помещенных на виду. Изящный диффузор из дутого стекла, с отделкой transparent или army green, подчеркивает источник света, находящийся внутри.

Gask - это эффектная лампа, используемая как по отдельности, так и в композиции из нескольких ламп, с установкой на потолочном креплении, используя две разных отделки, чередуя прозрачность и матовость. Gask сочетает в себе ретро-стиль с практичной современностью, отсылки к прошлому и современный образ жизни.

## CHI

Gask 是一款效果显著的小型悬吊灯。仿若出自一座20年代的商场或是一座储放工作用具的仓库,但亦可令人联想至古代美索不达米亚地带神圣的金字塔形梯田神塔。

Gask是一系列具有明显感官对比的材料之完美结合—玻璃、钢、黄铜—共同创造出一种完美融合。钢制框架的饰面为哑黑色,粗糙且具有强烈的工业风情,并通过肉眼可见的黄铜螺栓与灯罩相连。精致的吹制玻璃灯罩,拥有transparent(透明色)或 army green(军绿色)两种饰面,刻意凸显其内部光源的存在。

无论是单盏还是组合于底盘上,亦或是在透明与哑光的游戏中穿插两种不同饰面, Gask 都是一款具有冲击力的灯件。以其怀旧气息邂逅现代之中的实用感, Gask将回顾往昔与当代生活风尚完美结合。

## DEU

Wie ein Tropfen glühenden Materials scheint Glass Drop die magische und schwer fassbare Natur des mundgeblasenen Glases in dem Moment darzustellen, in dem es sowohl flüssig als auch fest ist, kurz bevor es Gestalt annimmt.

In der Ausführung chrome hat sie eine Oberfläche, die im ausgeschalteten Zustand wie ein Spiegel reflektiert, während sie im eingeschalteten Zustand so aussieht, als ob das Licht das Metall auflöst und die Farbe des Lichts zum Vorschein bringt: eine Leuchte, die ihre Persönlichkeit mit einer einfachen Berührung des Schalters verändert. Glass Drop ist auch in einer hellen Version white erhältlich, die extrem vielseitige Gestaltungsmöglichkeiten bietet.

Glass Drop ist besonders eindrucksvoll in mehreren Kompositionen, wie ein aus vielen Anhängern zusammengesetztes Juwel, das Funktionalität und Harmonie im Zeichen vereint.



## ESP

Como una gota de material incandescente, Glass Drop parece representar la naturaleza mágica y escurridiza del vidrio soplado en el instante en que es al mismo tiempo líquido y sólido.

En la versión chrome (cromo) tiene una superficie que cuando está apagada refleja como un espejo, mientras que cuando está encendida parece que la luz funda el metal revelando el color de la luz: una lámpara que cambia de personalidad simplemente tocando el interruptor. Glass Drop también está disponible en una cándida versión white (blanca) que ofrece una gran versatilidad de ambientación.

Glass Drop tiene un gran efecto en composiciones múltiples, como una joya formada por muchos colgantes que une funcionalidad y armonía.

## FRA

Comme une goutte de matériau incandescent, Glass Drop semble représenter la nature magique et éphémère du verre soufflé à l’instant où il est fluide et solide à la fois, juste avant de prendre forme.

Dans la version chrome, la surface reflète comme un miroir à lumière éteinte, tandis qu’à lumière éclairée, elle semble dissoudre le métal en révélant sa couleur : une lampe qui change de personnalité en effleurant simplement l’interrupteur. Glass Drop est également disponible dans une version candide white qui offre une polyvalence extrême d’adaptabilité à tous les types d’espaces.

Glass Drop est de grand effet dans les compositions multiples, comme un joyau composé de pendentifs, dans un binôme de fonctionnalité et d’harmonie.

## RUS

Как капля раскаленного стекла, Glass Drop олицетворяет волшебную и неуловимую природу дутого стекла в тот момент, когда оно является одновременно жидким и твердым, непосредственно перед тем, как принимает определенную форму.

В версии chrome в выключенном состоянии поверхность отражает предметы, как зеркало, а когда лампа включена, кажется, что свет растворяет металл, открывая его тональность: эта лампа меняет свой вид при простом нажатии выключателя. Glass Drop выпускается также в белоснежном варианте white, прекрасно адаптируемом к любому интерьеру.

Glass Drop создает особенно сильный эффект, когда используется в множественных композициях, как ювелирное украшение, состоящее из множества подвесок, сочетающих в себе функциональность и гармонию.

## CHI

仿若一滴白炽物质, Glass Drop 仿佛代表着吹制玻璃在即将成形之前的同时,以液态或固态呈现的神奇玄妙的本质。

chrome(铬色)版本,有着在关灯时会像一面镜子般反射的表面,而在亮灯时,光线似乎在对其颜色的拾捡中融化着金属:是一款只需轻触开关便可转变个性的灯件。Glass Drop还供有一款率真的white(白色)版本,为周围环境赋予极致的多用性。

Glass Drop在多样组合时效果更佳,就像一颗由许多吊坠组成的珠宝,且兼具标志的多用性与和谐性。

---

## DEU

Formen, die an große Fabrikrohre erinnern, entmaterialisiert und erleichtert durch ihren textilen Charakter. Dies sind die Pipe Leuchten, die sich durch ihre beachtliche Größe und das warme, über die gesamte Fläche gestreute Licht auszeichnen.

Pipe entstand aus der Forschung von Diesel in der Welt der Stoffe und ist in gebleichtem Rohleinen oder mit gedrucktem Dekor erhältlich. Die unregelmäßige Webart verwandelt sich in ein leuchtendes Dekor, das dem Stoff weitere Emotionen verleiht und den traditionellen Lampenschirm revolutioniert.

Erhältlich in zwei Größen, Medium und Large, ist Pipe eine architektonische Präsenz, die allein oder in Gruppen von mehreren Elementen eingesetzt werden kann, um einen Raum zu beleuchten, zu charakterisieren und sogar zu definieren.

---

## ESP

Formas que recuerdan las grandes tuberías de una fábrica, desmaterializadas y más ligeras gracias a su naturaleza textil. Son las lámparas Pipe, que se caracterizan por el gran tamaño y la luz cálida que se difunde por toda la superficie.

Pipe nace de la investigación Diesel en el mundo de las telas y está disponible de lino en bruto blanqueado o con adorno impreso. La trama irregular se transforma en un adorno luminoso añadiendo más emoción a la tela y revolucionando la pantalla tradicional.

Disponible en dos tamaños, Medium y Large, Pipe es una presencia arquitectónica que puede utilizarse sola o en grupos de varios elementos para iluminar, caracterizar e incluso definir un espacio.

---

## FRA

Des formes qui rappellent les grands conduits des usines, dématérialisés et allégés par leur nature textile. Ce sont les lampes Pipe qui se caractérisent de par leurs dimensions importantes et la chaude lumière diffuse sur toute la surface.

Pipe provient de la recherche Diesel dans l'univers des tissus et est disponible en lin brut blanchi avec impression. La trame irrégulière se transforme en décoration lumineuse, pour encore plus d'émotion et un abat-jour complètement revisité.

Disponible en deux dimensions, Medium et Large, Pipe se veut une présence architecturale à utiliser seule ou à plusieurs éléments regroupés, pour illuminer, caractériser, voire définir un espace.



---

## RUS

Формы, напоминающие большие фабричные трубы, дематериализованные и облегченные благодаря текстилю. Светильники Pipe отличаются большими размерами и теплым светом, рассеянным по всей поверхности.

Pipe была разработана фирмой Diesel, проводящей исследования в текстильной области. Этот светильник выпускается из выбеленного необработанного льна или ткани с нанесенным декоративным узором. Неровная текстура превращается в световой узор, добавляя дополнительную красоту ткани и преобразуя идею традиционного абажура.

Выпускаемый в двух размерах, Medium и Large, светильник Pipe - это архитектурный элемент, который можно использовать отдельно или в групповых композициях, состоящих из нескольких частей, чтобы освещать, придавать характер и подчеркивать пространство.

---

## CHI

形状令人联想起工厂中的大型管道,以其织物本质而达到非物质化与轻便化。它们是Pipe灯件,其特征体现于重要的尺寸及遍布整个表面的温暖散射光线上。

Pipe 诞生于Diesel 在织物领域中的研究下,供有漂白粗亚麻或印花装饰两种版本。不规则的纹理转换为一种明朗的装饰,为织物凭添更多情感并革新了传统灯罩。

提供两种尺寸,Medium 和 Large,Pipe是一款可单独使用或是多种元素组合使用的建筑体系灯件,能够为一块空间照明、添彩并定义。

## DEU

Inspiriert von den Pollern, die in der Stadtlandschaft zu finden sind, ist Urban Concrete ein Beleuchtungskörper, der mit einer von einem Haken gekrönten Kuppel klare Linien und feste Oberflächen ausbalanciert.

Während die Metallkuppel eine Illusion von Schwere erzeugt, ist Urban Concrete sehr leicht und verleiht mit seinen drei Oberflächen – soft gray, tough gray und pink dust – und der weißen Innenfläche jedem Interieur einen Hauch von Robustheit und Raffinesse. Erhältlich in vier Größen (25, 50, 60 und 80 cm), ist Urban Concrete für unterschiedliche Verwendungszwecke und Interieurs im privaten und öffentlichen Bereich konzipiert. Die 25-cm-Kuppel ist an einem einzigen tragenden Kabel aufgehängt und kann auch auf mehrflamigen Baldachinen installiert werden, um einzigartige Pop- und Cluster-Kompositionen mit einem ausgewogenen Verhältnis zwischen Solidität und Schlichtheit zu kreieren.

## ESP

Inspirada en los bolardos que se encuentran en el paisaje urbano, Urban Concrete es una lámpara que busca el equilibrio en las líneas limpias y las superficies sólidas con una cúpula coronada por un gancho de elevación.

Si bien la cúpula de metal torneado evoca un bloque de hormigón y crea una ilusión de pesadez, en realidad Urban Concrete es una lámpara colgante muy ligera y dúctil. Gracias al contraste entre los tres acabados de hormigón – soft gray (gris suave), tough gray (gris fuerte) y pink dust (rosa pálido) – y el blanco cándido de la superficie interna del difusor, Urban Concrete le da un toque de solidez y sofisticación a cualquier interior.

Disponibile en cuatro tamaños (25, 50, 60 y 80 cm), Urban Concrete se ha concebido para diferentes usos y tipos de interiores domésticos y públicos. La cúpula de 25 cm cuelga de un solo cable portante y también se puede instalar en múltiples florones para crear composiciones opuestas y grupos únicos con un juego de equilibrios entre solidez y simplicidad.

## FRA

S'inspirant des bornes que l'on trouve dans le paysage urbain, Urban Concrete est une lampe qui conjugue les lignes épurées et les surfaces solides avec un dôme surmonté d'un crochet de levage.

Alors que le dôme en métal tourné rappelle un bloc de ciment et crée une impression de lourdeur, Urban Concrete est en réalité une lampe à suspension très légère et ductile. Grâce au contraste entre les finitions en ciment – soft gray, tough gray et pink dust – et le blanc candide de la surface intérieure du diffuseur, Urban Concrete présente une touche de matérialité et de raffinement dans tous les espaces intérieurs.

Disponibile en quatre tailles (25, 50, 60 et 80 cm), Urban Concrete est conçue pour différents emplois et typologies d'intérieurs domestiques et publics. La coupole de 25 cm est suspendue à un unique câble portant et peut être installée sur des patères multiples pour créer des compositions pop et des clusters uniques, dans un jeu d'équilibre entre solidité et simplicité.



## RUS

Этот светильник создан под вдохновением бетонных столбов, которыми усеян городской ландшафт. Urban Concrete представляет собой светильник, уравнивающий чистые линии и прочные поверхности с куполом, увенчанным подъемным крюком.

Точный металлический купол напоминает бетонный блок и создает иллюзию тяжести, в действительности Urban Concrete – это очень легкий и универсальный подвесной светильник. Благодаря контрасту бетонной отделки – soft gray, tough gray и pink dust – и белоснежной внутренней поверхности диффузора, Urban Concrete придает изысканность и материальность любому интерьеру.

Urban Concrete имеет четыре варианта размеров (25, 50, 60, и 80 см) и предназначен для различных применений в домашних и общественных помещениях. Купол размером 25 см подвешен к одинарному несущему шнуру, он может устанавливаться на множественные потолочные крепления для создания контрастных композиций и уникальных кластеров, характеризующихся прочностью и простотой.

## CHI

灵感源自城市景观中的系缆柱, Urban Concrete是一款结合着干净线条与坚固表面的灯件,呈圆顶形且悬吊于一根吊钩上。

尽管弯转的金属圆顶会让人联想起混凝土块并营造一种沉重的错觉,但Urban Concrete事实上却是一款非常轻巧坚韧的悬吊灯。凭借三种混凝土饰面之间的对比– soft gray(柔灰色)、tough gray(坚灰色)和 pink dust(尘粉色) – 以及灯罩内表的率真白色, Urban Concrete会为任何室内装饰增添坚固性与精致感。

针对各种用途以及居家和公共室内环境, Urban Concrete提供四种不同尺寸(25、50、60和80厘米)。25厘米的圆顶悬吊于单根电源线上,也可装置于多样底盘上,以一种介于坚固性与简约性之间的平衡游戏营造流行的组合与独特的群簇。

## DEU

Vinyl ist eine äußerst graphische Leuchte. Sie besteht aus einer Metallplatte mit einer kreisförmig eingravierten Textur, die an eine Schallplatte erinnert, Klangschwingungen emuliert und gleichzeitig das Licht auf fesselnde Weise für das menschliche Auge aufteilt.

Vinyl ist eine vielseitig einsetzbare Decken- und Wandleuchte aus Metall, die sich auch perfekt als Hängeelement eignet. Sie ist in zwei Größen mit 60 und 32 cm Durchmesser und in zwei Ausführungen erhältlich: silver und deep black.

Für Wand- und Deckenausführungen empfehlen wir die Verwendung von kuppelverspiegelten Leuchtmitteln, für einen indirekten Streiflicht-Effekt an der Oberfläche, die zu vibrieren scheint.

Ihr dynamisches Design macht diese dekorative Leuchte perfekt für öffentliche Räume.

Leg Vinyl auf und genieße das Licht!

## ESP

Lámpara sumamente gráfica, Vinyl está formada por una superficie metálica con un dibujo circular grabado similar a un disco de vinilo que parece evocar las vibraciones sonoras mientras descompone la luz de forma cautivadora para el ojo humano.

Vinyl es una lámpara versátil de techo y de pared de metal torneado perfecta también como elemento de suspensión. Está disponible en dos tamaños, 60 y 32 cm de diámetro, y dos acabados: silver (plateado) y deep black (negro intenso).

Para las variantes de pared y techo se recomienda utilizar bombillas con casquillo apantallado para conseguir un efecto de luz indirecta y paralela a la superficie que parecerá que vibra.

Su dinamicidad hace que esta lámpara decorativa sea perfecta para los espacios públicos. ¡gírad el vinilo y disfrutad de la luz!

## FRA

Extrêmement graphique, Vinyl se compose d'une plaque de métal avec texture gravée circulaire rappelant un disque de musique, émulant les vibrations sonores tout en divisant la lumière d'une manière captivante à l'œil humain.

Vinyl est une lampe polyvalente de plafond, de mur et de suspension en métal tourné.

Disponible en deux tailles, 60 et 32 cm, et deux finitions : silver et deep black.

Pour les variantes murales et de plafond, l'utilisation d'ampoules à calotte est préconisée pour un effet de lumière indirecte et rayonnant en surface, qui donnera l'impression de vibration.

Grâce à son design dynamique, cette lampe décorative est parfaite pour les espaces publics. Faites tourner le disque et appréciez la lumière!



## RUS

Графический светильник Vinyl изготовлен из металлической пластины с кольцевой выгравированной текстурой, напоминающей виниловую пластинку, создающую ощущение звуковых колебаний, деля свет и создавая завораживающий для человеческого глаза эффект

Vinyl - это универсальный потолочный и настенный светильник из выточенного металла, который также может использоваться в качестве подвесного элемента. Он выпускается в двух размерах, диаметром 60 и 32 см, и двух вариантах отделки: silver и deep black.

Для настенных и потолочных вариантов мы рекомендуем использовать лампы с экранированными цоколями для создания эффекта непрямого света, касающегося поверхности и создающего иллюзию вибрации.

Его динамичный дизайн делает данный светильник прекрасно подходящим для общественных помещений. Включите пластинку и наслаждайтесь светом!

## CHI

一款图形感极强的灯具,Vinyl 由一块刻有类似于黑胶唱片的圆形图案的金属表面组成,仿佛在模拟声音震动的同时以迷人的方式将光线散入眼帘。

Vinyl是一款由车削金属制成的多功能天花板式和壁式灯件,也是作为悬吊式灯件的完美之选。

提供两种尺寸,60和32 厘米的直径,以及两种饰面:silver (银色)和deep black (深黑色)。

针对壁式和天花板式版本,建议使用屏光球形灯泡,以期在表面上制造一种间射光线的效果,仿佛是在震颤一般。

它那具有动感的标志使这款装饰性灯件非常适合公共空间。转动唱盘并享受光线吧!





Limited Warranty  
12 months  
for United States Only

#### Coverage

Lodes S.r.l., with headquarter in 30020 Marcon (VE), Via Pialoi 32 Italy, VAT N.: 02992370276 (hereinafter, "WARRANTOR") warrants that each WARRANTOR PRODUCT will be free from defects in material and workmanship for a period of twelve months from the date of shipment / delivery of the PRODUCT (that can be identified by the "Studio Italia Design" or "Lodes" trademark, trade name, or logo affixed to them). The Limited Warranty is referred to herein as "the Limited Warranty." The PURCHASER's sole and exclusive remedy under this Limited Warranty for defects in the PRODUCT shall be the repair, replacement or refund of the purchase price, in WARRANTOR's sole discretion, of the defective PRODUCT, or components thereof.

#### Not Covered

This Limited Warranty also does not apply to, and WARRANTOR shall have no liability or responsibility in respect of, damages or expenses relating to:

- The failure to properly store, transport, install or use the PRODUCT as, for example, specified in any manuals or other literature supplied by WARRANTOR, on WARRANTOR's website, or in accordance with any applicable laws, codes, regulators or standards;

- Any PRODUCT purchased from any entity other than WARRANTOR;

- Alteration, change or modification of the PRODUCT, including its subcomponents, parts or assemblies;

- WARRANTOR also makes no warranty that a PRODUCT manufactured does not infringe the intellectual property or other proprietary rights of any third party;

- Accidents, misuse, abuse, abnormal use, improper use, negligent use, wilful misconduct, or use exceeding the recommended and permitted limits of the PRODUCT, and / or normal wear or deterioration;

- Any defect or non-conformity that has not been timely and promptly communicated in writing to WARRANTOR as set forth herein.

- Any damage, cost or expense caused by Act of God; or

- Loss of time, loss of use, inconvenience, loss of profits, lost business, lost business opportunities, damage to reputation, goodwill and any incidental or consequential damages arising out of or relating to the PRODUCT, or other matters not specifically covered hereunder.

#### Procedure

Upon delivery, PURCHASER shall, within one (3) business day, inspect the PRODUCT for conformity and visible defects. PURCHASER shall give WARRANTOR immediate written, specific and detailed notice of any non-conformities or defects regarding the PRODUCT. Upon receipt of the written notice of claim, WARRANTOR shall have the right to inspect the PRODUCT. In the event of a defect covered by this Limited Warranty, WARRANTOR will, at WARRANTOR's discretion, repair or replace the PRODUCT or any component of the PRODUCT or refund the purchase price for that particular PRODUCT. In the event that PURCHASER submits a warranty claim that, in the sole reasonable discretion of the WARRANTOR, is unfounded, the PURCHASER shall reimburse the WARRANTOR all reasonable costs incurred by the WARRANTOR

in evaluating the warranty claim (i.e. travel, lodging, expert evaluations, etc.). WARRANTOR must approve, in advance and in writing, all repairs or replacements covered under or performed pursuant to this Limited Warranty. Any warranty repairs or service must be performed exclusively by WARRANTOR or other authorized representative of WARRANTOR or by another servicing facility pre-approved in writing by WARRANTOR. Acceptance of any Limited Warranty claim is not an admission that any PRODUCT or any of its component parts are defective.

The PURCHASER forfeits any rights it may have under this Limited Warranty if the PURCHASER does not follow the procedure described herein. All requests and notices under this Limited Warranty shall be directed to:

Lodes S.r.l.,  
Via Pialoi n. 32, 30020  
Marcon (VE), Italy  
E-mail: legal@lodes.com  
Fax: +39 0414 56 73 37

#### Limitation of Damages

LIMITATION OF DAMAGES. Except as expressly provided by this Limited Warranty, WARRANTOR SHALL NOT BE RESPONSIBLE FOR ANY INCIDENTAL OR CONSEQUENTIAL DAMAGES ASSOCIATED WITH THE USE OR NON-USE OF THE PRODUCT OR A CLAIM UNDER THIS LIMITED WARRANTY, WHETHER THE CLAIM IS BASED ON CONTRACT, TORT OR OTHERWISE. The foregoing statements of warranty are exclusive and in lieu of all other remedies or damages. Some States do not allow the exclusion or limitation of incidental or consequential damages, so only in this case this limitation or exclusion may not apply to you.

This Limited Warranty shall be the sole and exclusive remedy available to the PURCHASER with respect to this PRODUCT. In the event of any alleged breach of any warranty or any legal action brought by the PURCHASER, based on breach of warranty, alleged negligence or other tortious conduct by WARRANTOR, the PURCHASER's sole and exclusive remedy will be the repair or replacement of any defective PRODUCT as stated herein. In no event shall the liability of the WARRANTOR exceed the purchase price of the PRODUCT.

#### Disclaimer

ANY IMPLIED WARRANTY OF MERCHANTABILITY OR FITNESS FOR A PARTICULAR PURPOSE AND ALL IMPLIED WARRANTIES ARISING FROM A COURSE OF DEALING, USAGE OF TRADE, BY STATUTE OR OTHERWISE, IS HEREBY STRICTLY LIMITED TO THE TERM OF THIS WRITTEN WARRANTY. This Limited Warranty shall be the sole and exclusive remedy available to the PURCHASER with respect to this PRODUCT. In the event of any alleged breach of any warranty or any legal action brought by the PURCHASER based on alleged negligence or other tortious conduct by WARRANTOR, the PURCHASER'S sole and exclusive remedy will be repair or replacement of defective materials or refund of the purchase price, as stated herein.

#### Transfer of Limited Warranty

This warranty is made by WARRANTOR with only first PURCHASER of the PRODUCT and does not extend to any subsequent PURCHASER or any third parties. The unexpired portion of this Limited Warranty may not be transferred to any entity.

#### Applicable Law

This Limited Warranty shall be deemed to have been particularly negotiated between parties. The parties expressly acknowledge and irrevocably agree that any and all claims or disputes arising out of or otherwise relating to this Limited Warranty shall be decided exclusively by Court of Milan under Italian Law with the exclusion of any courts of any

place. PURCHASER expressly waives any provision of law in the jurisdiction in which PURCHASER is located or any other potentially applicable law which conflicts with any provision of this Limited Warranty at any time.

#### Other Rights

Your acceptance of delivery of The PRODUCT constitutes your acceptance of the terms of this Limited Warranty. This Limited Warranty gives you specific legal rights, and you may also have other rights which vary from state to state. If any term or provision of this Limited Warranty is invalid or unenforceable under any local, state, or federal law, statute, judicial decision, regulation, ordinance, executive order or other rule of law, such term shall be deemed reformed or deleted, but only to the extent necessary to comply with such statute, regulation, ordinance, order or rule and the remaining provisions of this Limited Warranty shall remain in full force and effect.

#### Entire Agreement

This document alone contains the entire Limited Warranty given by WARRANTOR in respect of the PRODUCT. Nothing in WARRANTOR's product literature, marketing materials, advertisements and technical specifications expand or enlarge the scope of this Limited Warranty. There are no terms, promises, conditions or warranties regarding the PRODUCT other than those expressly contained herein. WARRANTOR specifically does not authorize any person, including but not limited to any dealer or other agent or employee of WARRANTOR, to extend the time, scope, terms or conditions of this Limited Warranty or to create or assume for WARRANTOR any other obligation or liability with respect to the PRODUCT or other products designed, manufactured or sold by WARRANTOR. All terms of this Limited Warranty are contractual and not mere recitals, and constitute material terms of this Limited Warranty. It is agreed and acknowledged that the provisions of this Limited Warranty allocate the risks between WARRANTOR and PURCHASER, that WARRANTOR's pricing reflects this allocation of risk, and but for this allocation and limitation of liability, WARRANTOR would not have entered into this Limited Warranty.

The agents, employees, and dealers of WARRANTOR Products are not authorized to make modifications to this limited warranty or make additional warranties binding on the WARRANTOR.

THIS DOCUMENT AND ALL PROVISIONS CONTAINED HAS BEEN SPECIFICALLY AGREED BETWEEN THE PARTIES.

# NOTES

Lodes S.r.l., via Pialoi 32,  
30020 Marcon (Venezia) Italy  
T +39 041 45 69 266  
info@lodes.com

Diesel Living with Lodes - 2021 Lighting Assortment

Art Direction: Diesel Creative Team

Graphic design: Nava Press

Photography:

Truetopia

Jeremias Morandell

Paola Pansini

Mitch Payne

Thomas Albdorf

Copywritings: Lodes

Color separation

and printing: Nava Press



WITH  
LODES

[www.lodes.com/diesel](http://www.lodes.com/diesel)